

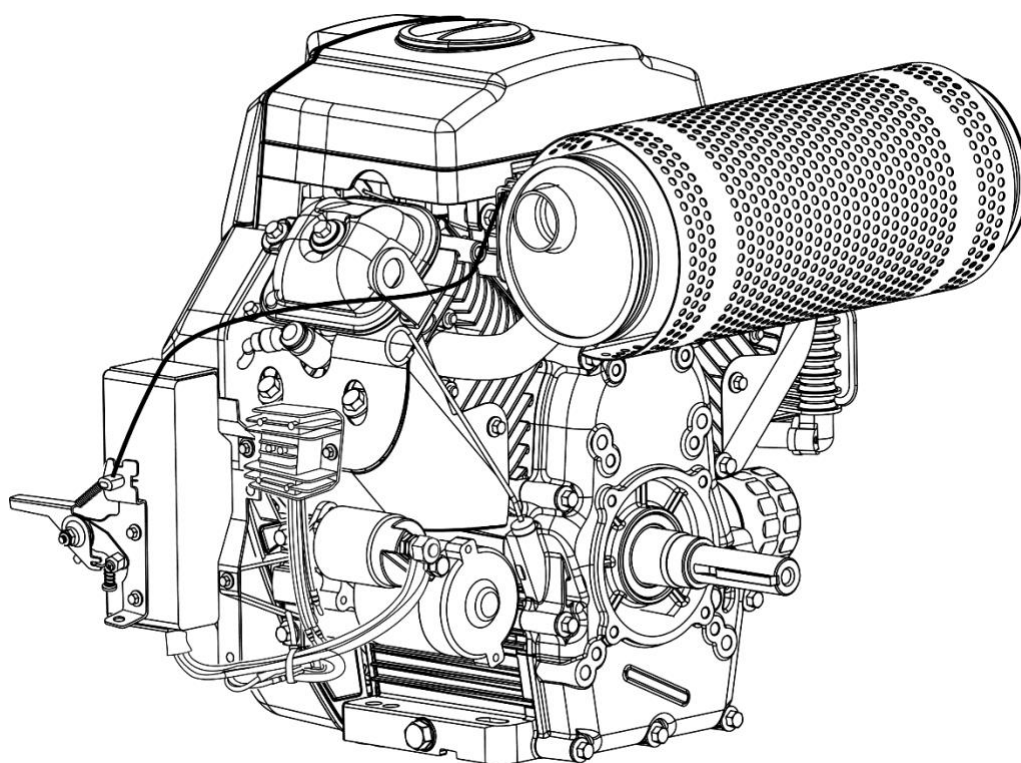

R740

Service Manual



Chongqing RATO Technology Co., Ltd.

This Manual covers specifications that shall be followed in the process of regular maintenance and troubleshooting of generator sets.

Make sure the equipment's maintenance staff can refer to this Manual at any time.

This Manual describes correct methods to service this equipment. The Company does not undertake any liability for any personal casualty and equipment damage caused due to ignoring these rules.

Note:

The copyright of this Manual belongs to the Company. It is not allowed to reproduce this Manual without written consent of the Company, and corresponding responsibility will be taken for violation.

Safety Warnings

The personal and property safety of you and others is very important. Please carefully read the three kinds of extremely important safety warnings that we have described in the Service Manual and on the decals of the generator sets. There is the symbol  in front of each safety warning. Details are as follows:



Failure to follow instructions will lead to extremely serious injuries.



Failure to follow instructions may lead to very serious injuries.



Failure to follow instructions may lead to minor injuries.



Failure to follow instructions may lead to damage to your generator sets and other properties.

Contents

Part I Introduction	1
1-1 Engine components	1
1-1-1 Structural features	1
1-1-2 Gasoline engine model and No.	2
1-2 Product parameters	2
1-3 Service standards	3
Part II Maintenance	4
2-1 Maintenance list	4
2-2 Oil	4
2-3 Air filter	5
2-4 Spark plug	6
2-5 Adjustment of valve clearance	7
2-6 Governor	9
Part III Fault Judgement and Repair	10
3-1 Fault judgement	10
3-1-1 Start difficulty	10
3-1-2 Underpower	11
3-1-3 Unstable speed	12
3-1-4 Unable to ignite	12
3-1-5 Overheating of general-purpose gasoline engine	13
3-1-6 Abnormal sound	13
3-1-7 Failure of power generation of the generator	13
3-2 Pre-maintenance preparations	14
3-2-1 Safety factors	14
3-2-2 Special tools	15
3-3 Disassembly chart	16
3-4 Gasoline engine	16
3-4-1 Air director	16
3-4-2 Impeller/flywheel/ignition coil/charging coil	17
3-4-3 Air filter	20
3-4-4 Gasoline pump and carburetor	20
3-4-5 Cylinder head/valve	26
3-4-6 Muffler	31

Disassembly and assembly	32
3-4-7 Starting control box	39
3-4-8 Starter motor	43
3-5 Electrical schematic diagram (electric starting type).....	44
Appendix	45

Part I Introduction

1-1 Engine components

1-1-1 Structural features

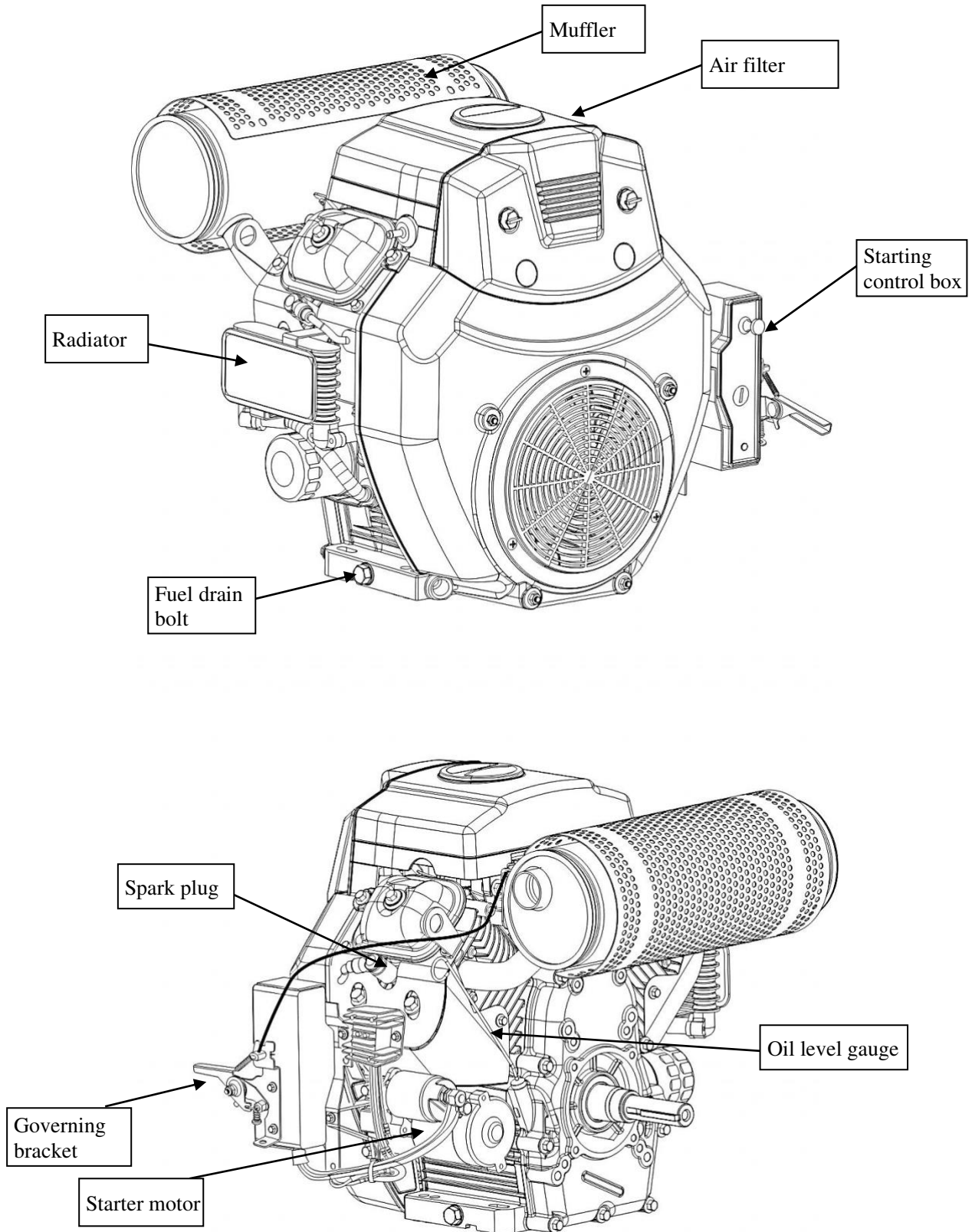

1-1-2 Gasoline engine model and No.

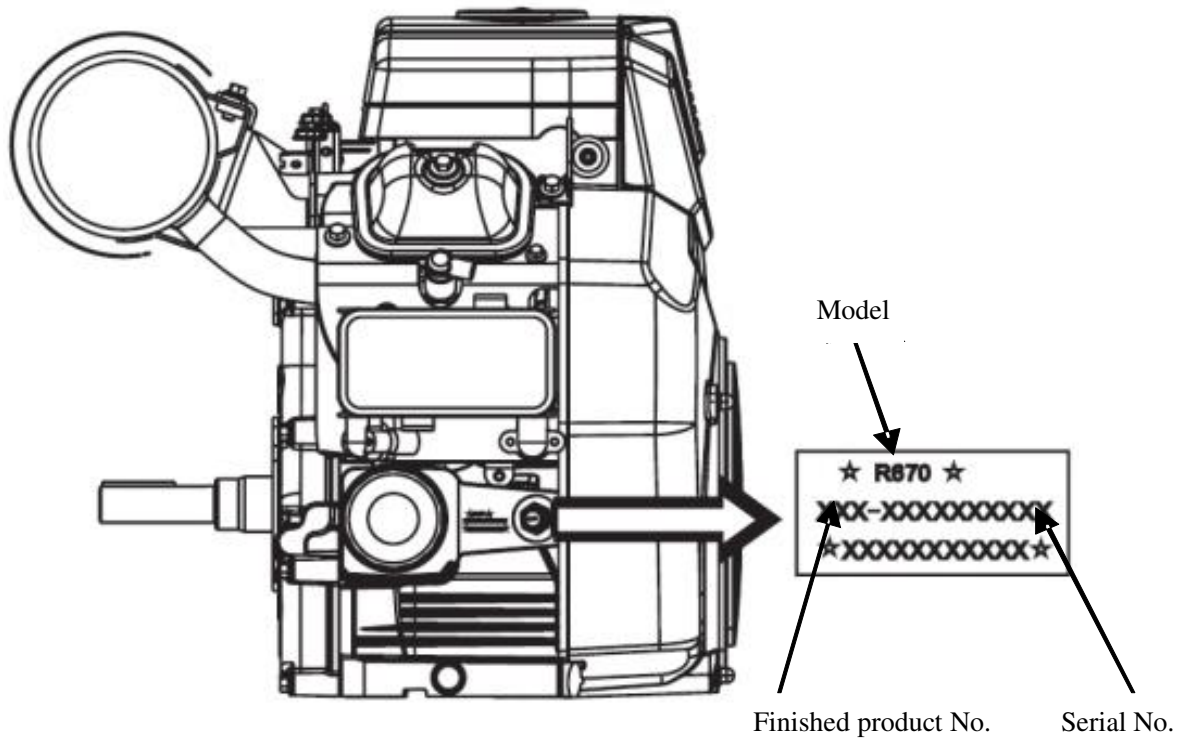

1-2 Product parameters

	Gasoline engine	R740D
Gasoline engine	Type of gasoline engine	Air-cooled, 4-Stroke, OHV, V-Twin cylinder
	Displacement (cc)	739.3
	Ignition system	Transistor magnet ignition (contactless)
	Fuel tank volume (L)	None
	Minimum fuel consumption rate, g/kw.h	≤374
	Oil capacity (L)	1.6L
	No-load speed	3800
	Rated output power (kW)	15
	Maximum output power (kW)	16.8
	Big air filter	•
	Big muffler	•
	Big oil tank	•
	General-purpose assembly	Fuel level indicator
Voltmeter		•
Three-in-one digital display		•
Voltage regulator (AVR)		•
Oil alarm system		•
Circuit breaker		•
Electric starting accessory		•

Note: • means provided; - means not provided

1-3 Service standards

Gasoline engine

Part	Item	Standard	Service limit
Gasoline engine	Maximum no-load speed	3180-3800 rpm	--
	Cylinder pressure	1.25MPa/1400rpm	--
Cylinder	Cylinder bore diameter	82mm	82.195mm
Cylinder head cover	Warping	--	0.10mm
Piston	Outer diameter of piston skirt	81.962~81.98mm	81.86mm
	Piston-cylinder clearance	0.02~0.058mm	0.12mm
	Inner diameter of piston pinhole	17.004~17.01mm	17.048mm
	Outer diameter of piston pin	16.992~16.998mm	16.954mm
	Piston pin-piston pinhole clearance	0.006~0.018mm	0.08mm
Piston ring	Piston ring side clearance: top ring/ring 2	0.03~0.05/0.02~0.04mm	0.135mm
	Oil ring	0.04~0.11mm	0.31mm
	Piston ring closing clearance: top ring/ring 2	0.2~0.35/0.35~0.5mm	1.0mm
	Oil ring	0.2~0.7mm	1.5mm
	Piston ring width: top ring/ring 2/oil ring	1.17~1.19mm 1.91~1.97mm	0.77mm 1.46mm
Connecting rod	Inner diameter of small end	17.005~17.016mm	17.052mm
	Inner diameter of big end	40.01~40.022mm	40.066mm
	Big end oil film clearance	0.03~0.054mm	0.12mm
	Small end side clearance	0.2~0.6mm	1.0mm
Crankshaft	Outer diameter of main journal	39.968~39.98mm	39.92mm
Air valve	Valve clearance Intake	0.1~0.15mm	--
	Outer diameter of valve stem Exhaust	0.15~0.2mm	--
	Conduit inner diameter Intake	6.466~6.475mm	6.318mm
	Conduit inner diameter Exhaust	6.451~6.46mm	6.275mm
	Tappet clearance Intake/exhaust	6.5~6.515mm	6.562mm
	Valve seat contact width Intake	0.025~0.049mm	0.10mm
	Free length of spring Exhaust	0.04~0.064mm 0.7~1.0mm 39.4mm	0.12mm 2.0mm 38mm
Camshaft	Cam height Intake	4.64~4.80mm	4.35mm
	Exhaust	4.64~4.80mm	4.35mm
	Outer diameter of journal	15.959~15.977mm	15.916mm
Crankcase cover	Inner diameter of camshaft bore	16~16.018mm	16.048mm
Carburetor	Float height	13.2mm	--
Spark plug	Clearance	0.7~0.8mm	--
Spark plug cap	Resistance	9~11kΩ	--
Ignition coil	Resistance Primary side	0.8-1.0Ω	--
	Ignition coil clearance Secondary side	5.9-7.1kΩ	--
		0.35~0.45mm	--

Part II Maintenance

2-1 Maintenance list

Good maintenance is the best guarantee to realize safe, economical and zero-fault operation. It is also conducive to environmental protection.

▲ WARNING

The exhaust gas of the engine contains toxic carbon monoxide. Please shut down the gasoline engine for maintenance.

If maintenance needs to be carried out while the engine is running, you should make sure that the work area is well ventilated.

Regular maintenance can ensure that the engine works in good condition. The maintenance schedule is as follows:

Maintenance period		Every time	1st month or 10 hours at the first time	Every 3 months or 20 hours	Every 6 months or 50 hours	Every year or 100 hours
Item						
Engine oil	Check-fill	√				
	Replace		√		√	
Air filter element	Check	√				
	Clean			√		
	Replace				√	
Spark plug	Clean-adjust				√*	
Spark arrester	Clean				√	
Valve clearance**	Check-adjust					√
Fuel pipe	Check	Every two years (please replace it if necessary)				
Cylinder head and piston	Clear carbon deposits**	Every 125 hours;				
*The item shall be replaced if necessary;						
**These items shall be maintained by the dealer authorized by our company, unless the user has proper tools and maintenance capability.						

NOTICE

- The oil shall be replaced every 10 h if it is frequently operated under high temperature or high load.
- The air filter element shall be cleaned every 10 h if it is frequently operated in dusty or harsh environment; the air filter element shall be replaced every 25 h if necessary.
- The maintenance shall be carried out according to the time shown in the table above for the spot inspection period and time.
- If the maintenance interval has expired, the maintenance shall be carried out according to the above table as soon as possible.

2-2 Oil

Replace the oil.

Warm up the gasoline engine (start the engine with no load for 10 minutes) and let it stand for another 40 minutes so that the oil can be drained quickly and cleanly.

- ①. Remove the fuel drain bolt. Then, open the fuel drain dipstick to drain the oil.
- ②. Install and tighten the fuel drain bolt.
- ③. Fill the oil to the specified position (as shown in the right figure), and check the oil level.
- ④. Install the oil dipstick.

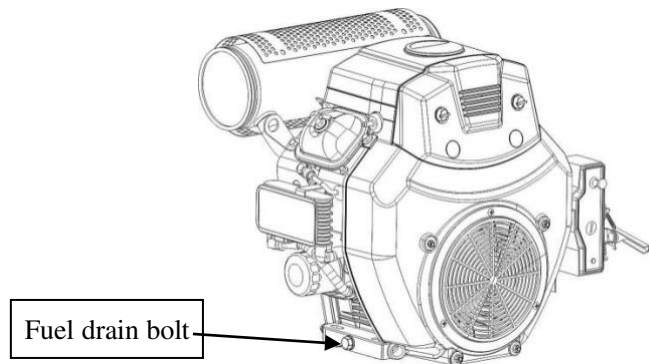

Gasoline engine oil capacity: 1.6L for R740; 1.8L for the first use; 1.6L from the second use.

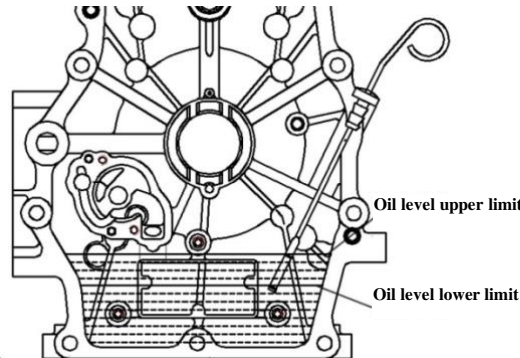

Recommended gasoline engine oil	<p>General purpose oil SAE15W-40 SJ, or SAE10W-30 gasoline engine oil equivalent to API SJ.</p> <p>※ At low temperatures (below 10°C), use (SAE10W-30) >.</p> <p>※ In cold weathers (below -15°C), use cold area oil SAE5W-30, or SAE5W-30 gasoline engine oil equivalent to API SJ.</p>
---------------------------------	---

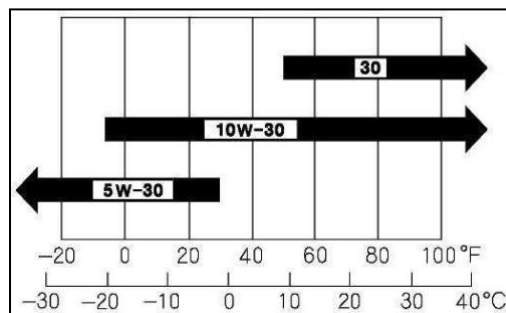

Environmental temperature

CAUTION Long-term and frequent contact with oil may lead to skin cancer. Although this is not certain, it is still recommended to avoid direct contact as much as possible. In case of contact, wash the skin that has been exposed to oil with soap and water immediately and thoroughly.

To protect the environment, please properly dispose of the waste oil. We strongly recommend you to: contain the waste oil with the sealed container and then send it to the local service station or the waste oil recycling center. Remember: Do not throw oil into the garbage or dump it on the ground or in the ditch.

2-3 Air filter

Dirty air filter will affect the flow of air into the carburetor. To prevent carburetor faults, please maintain the air filter regularly. (Please refer to 2-1 maintenance list for frequency, and the figure below for the method)

If it is used in the dusty environment, it should be maintained more frequently.

▲ WARNING

Cleaning the filter element with gasoline or flammable solvent may lead to fire or explosion. Please clean it with soapy water or nonflammable solvent.

NOTICE

Do not start the generator without air filter, otherwise it will accelerate the wear of the gasoline engine.

- 1) Twist out the locking handle assembly and remove the fan guard decoration sheet.
- 2) Twist out the locking nut assembly of the air filter and remove the air filter housing cover.
- 3) Remove the air filter buckle, and then remove the foam filter element and the paper filter element.

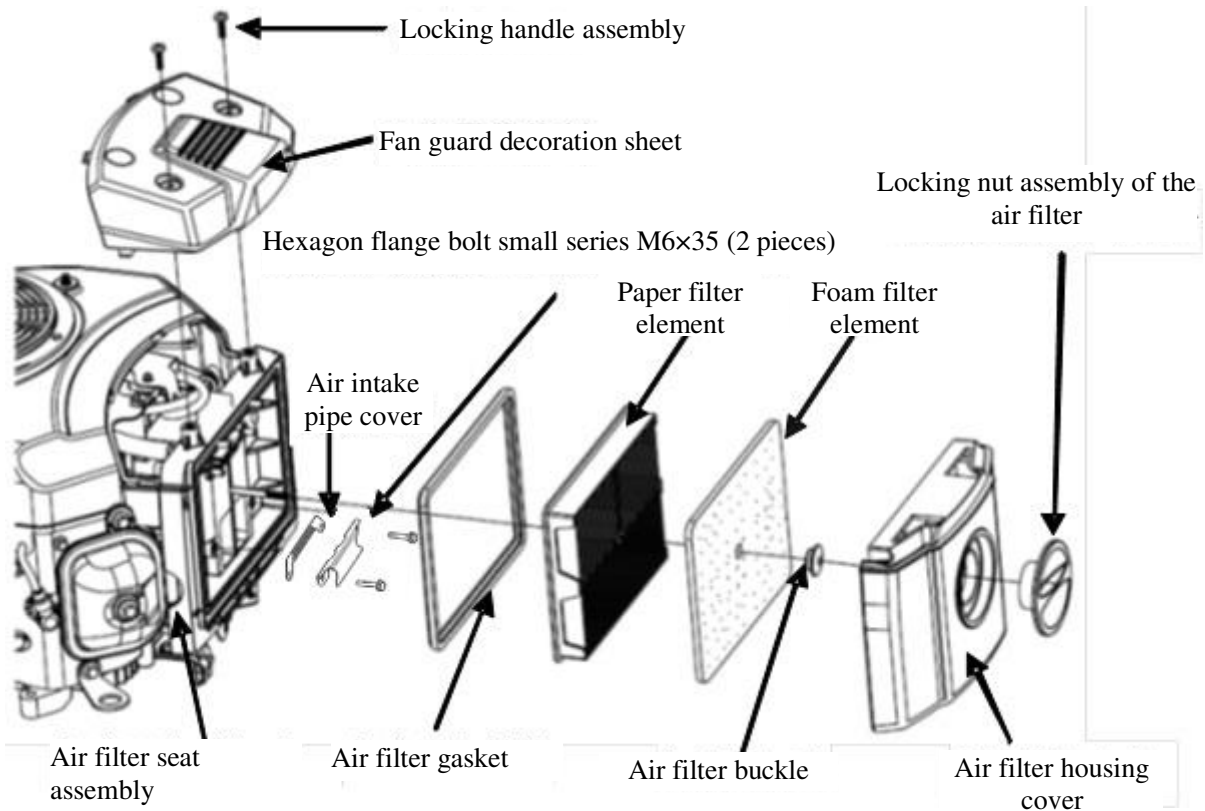

2-3-1 Inspection and cleaning

- 1) Check the two air filter elements for holes and cracks, and replace them if so.
- 2) Clean filter element

Foam filter element: wash it in warm soapy water and dry it thoroughly. Or wash it in non-flammable solvent, and dry it. Do not make the foam stained with oil.

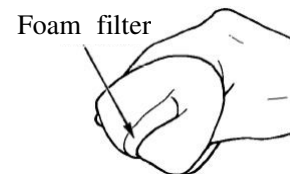

Paper filter element: place the filter element on a hard surface, gently fold it for several times to remove dirt, or use compressed air [no more than 207KPA, 2.1kg/cm²].

- 3) Wipe the dirt on the inside of the air filter housing and cover with a wet rag. Be careful not to let dirt enter the air duct connected to the carburetor.
- 4) Install the foam filter element inside the air filter cover. Reinstall the paper filter element and the air filter cover on the air filter housing.

2-4 Spark plug

Recommended spark plug model: F5RTC

- ①. Remove the spark plug cap.
- ②. Remove the spark plug with the spark plug socket wrench.
- ③. Visually inspect the spark plug insulator for damage. If the insulator is damaged, replace it with a new one. If the electrode has carbon deposits, clean it with a wire brush.

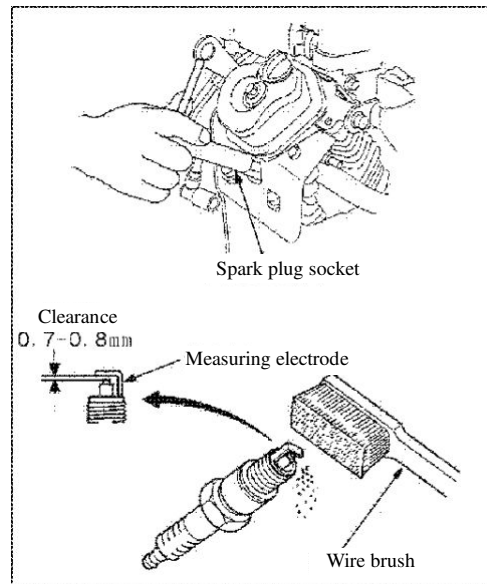

- ④. Measure the spark plug clearance with feeler gauge. The proper clearance shall be 0.70-0.80 mm; if adjustment is required, tap (when the clearance is large) it or gently pry up the electrode with a straight screwdriver (the gap is too small).
- ⑤. Check that the spark plug washer is in good condition.
- ⑥. Install the spark plug, tighten it on the cylinder head with a spark plug socket wrench, and install the spark plug cap.

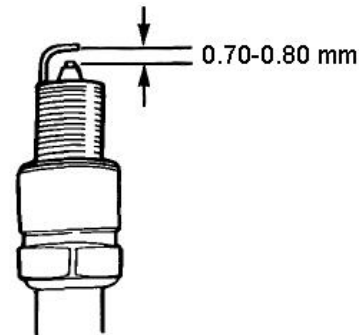

In order to prevent disorderly thread when installing the spark plug, first screw in the spark plug with hand in the direction indicated by the arrow (on the threaded hole of the cylinder head), and then tighten it with the special socket.

If a new spark plug is installed, an additional 1/2 turn shall be tightened after pressing the washer.

If a used spark plug is reinstalled, an additional 1/8-1/4 turn shall be tightened after pressing the washer.

Spark plug torque value: 22 ± 2 N·m

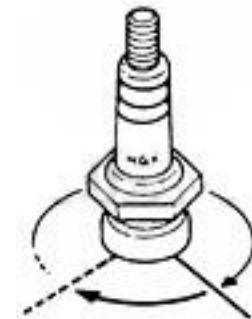

2-5 Adjustment of valve clearance

There is a certain valve clearance between the tail end of the valve stem of the gasoline engine and its transmission part to prevent the normal operation of the gasoline engine from being influenced by part expansion and contraction. During work, too large valve clearance will lead to poor exhaust, which will not only affect the dynamic performance of the gasoline engine but also increase noise (abnormal valve noise); while, too small valve clearance will lead to loose valve closing, which will result in the failure of normal operation of the gasoline engine and may result in the damage to the working surface of the parts of the valve train.

Generally, the valve clearance of the gasoline engine must be checked and adjusted after 1 year or 300h hours of use.

NOTICE

The valve clearance must be measured when the gasoline engine is cold.

NOTICE

Please note that there will be oil leakage when the cylinder head cover is disassembled.

- 1) Remove the cylinder head cover bolt and the cylinder head cover.
- 2) Remove the air director plate.
- 3) Rotate the flywheel to align the mark on the flywheel with that of the air director. The No. 1 cylinder valve clearance can be adjusted.
- 4) Insert a feeler gauge between the valve and the valve rocker arm to check the clearance

- 5) Then, rotate 270°, and adjust No. 2 cylinder valve clearance.

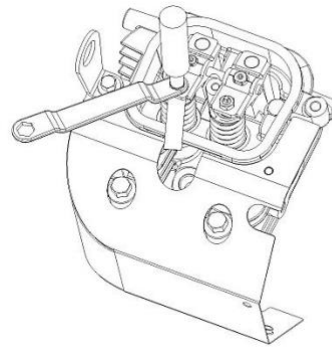
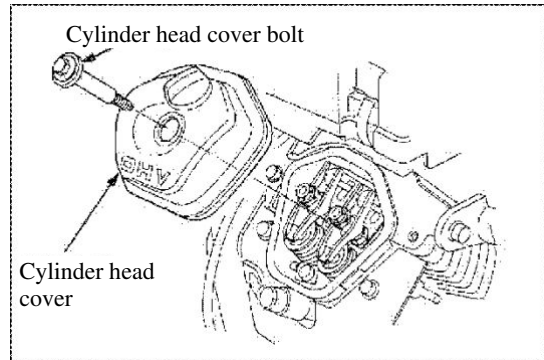

Adjust the valve clearance

Adjustment steps: unscrew the locking nut; rotate the adjusting nut to obtain the correct valve clearance; tighten the locking nut.

Valve clearance	Intake	0.1±0.02mm
	Exhaust	0.15±0.02mm

Adjusting screw	Valve clearance
Tighten	Decrease
Loosen	Increase

NOTICE Too large clearance: Late opening of intake and exhaust valves shortens the intake and exhaust time, reduces the valve opening height, changes normal valve timing and decreases the gasoline engine's power due to insufficient air intake and incomplete air exhaust; additionally, it also increases the impact of valve system parts and accelerates the wear.

Too small clearance: After the gasoline engine is operated, the part is heated and expanded to push the valve open and make the valve close loosely, which will cause air leakage, power reduction, and serious carbon deposition or burning on the sealing surface of the valve, and even cause that the valve strikes the piston.

2-6 Governor

- 1) Remove the air filter.
- 2) Unscrew the governing arm nut.
- 3) Check whether the throttle lever is in the high speed position.
- 4) When rotating the governing arm shaft counterclockwise, tighten the governing arm nut.
- 5) Move the governor arm to the low speed position and check whether the throttle arm is in contact with the throttle stop screw.

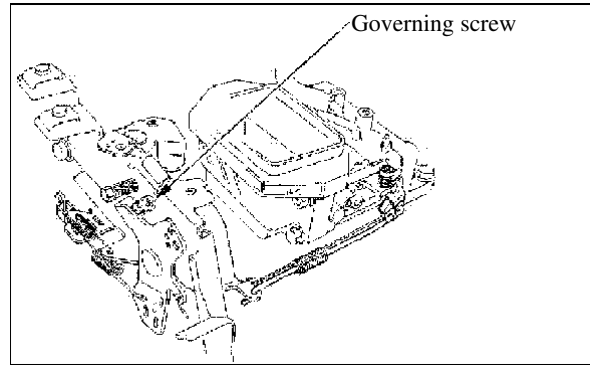

Maximum speed	3800rpm
---------------	---------

Too high speed	Rotate the adjusting screw counterclockwise.
Too low speed	Rotate the adjusting screw clockwise.

Part III Fault Judgement and Repair

3-1 Fault judgement

3-1-1 Start difficulty

Phenomenon			Cause		Remedy
Normal cylinder compression	Normal spark of spark plug	Abnormal fuel system	Impeded fuel flow or no fuel flow	No fuel in fuel tank	Refuel
				Clogged venthole of fuel tank cap	Dredge
				Main measuring hole is improperly adjusted or blocked	Re-adjust or clean, blow through
				Float needle hole is blocked	Remove needle valve for repairing, cleaning and blowing through
				The float is stuck or damaged	Repair the float
			Unobstructed fuel flow	Fuel is too dirty or deteriorated	Replace fuel
				There is water in fuel	Replace fuel
				There is excessive fuel in the cylinder	Drain the fuel, and wipe and dry spark plug electrode
	Normal fuel supply system	Spark of HV wire is normal	Spark plug is poor	Electrode is dirty with carbon deposit	Remove the dirt and carbon deposit
				Insulator is damaged, electrode is severe ablated	Replace the spark plug
				Electrode clearance is incorrect	Adjust electrode clearance
		HV wire has no spark	Spark plug is normal	HV wire is damaged	Replace the HV wire
				Ignition coil is damaged	Replace the ignition coil
				Magnet is demagnetized	Replace the flywheel
			The clearance between ignition coil and flywheel is abnormal	Adjust the clearance between ignition coil and flywheel	
Phenomenon			Cause		Remedy
Cylinder compression is poor	Normal fuel supply system	The ignition system is normal	Piston ring wear exceeds the limit	Replace it with complete set of new ring	
			Piston ring is broken	Replace it with complete set of new ring	
			Piston ring is stuck	Clear carbon deposit	
			The spark plug is not provided with sealing gasket or is not tightened	Mount the gasket and tighten it	
			Air leakage of joint face between the cylinder body and the cylinder cover	Check the flatness of joint face of cylinder pad and cylinder body and cylinder cover	
				And tighten cylinder cover bolts according to specified torque and sequence	
Valve leakage	Check valve clearance and valve tightness, repair when necessary				

If gasoline engine is still unable to be started, please send it to authorized dealer of the Company for overhaul.

Spark detection

▲ WARNING

(During the spark-over test of the spark plug) Ensure that there is no spilled fuel outside the gasoline engine and the spark plug is not soaked by fuel.

In order to prevent fire, keep sparks away from spark plug hole.

When doing testing to the spark plug, it is strictly prohibited to hold the spark plug HV wire with wet hand.

When operating, put the fuel switch in the "OFF" position, and drain off the fuel in the carburetor.

Remove the spark plug cap and spark plug.

Pull the starter handle to release unburned gas out of the cylinder.

Assemble spark plug cap.

Turn the generator switch to the "ON" position.

Ground the negative electrode (threaded part) of spark plug via the cylinder cover, pull the starter handle to observe the spark condition.

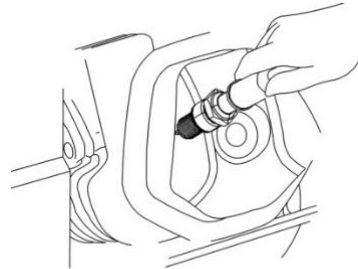

3-1-2 Underpower

Phenomenon	Cause		Remedy
When raising the throttle, the speed increases slowly, and the speed decreases or the engine shuts down when it is serious	Fuel supply system	There is air in oil way or the oil way is blocked	Exhaust and dredge oil way
		The main measuring hole is improperly adjusted	Adjust the main measuring hole again.
		Needle valve hole and the main hole are blocked in the carburetor	Clean, and blow through
		Fuel tank switch is clogged	Clean and replace damaged part
		There is carbon deposit in the combustion chamber.	Clear carbon deposit
		Blockage of air filter	Clean filter element
	Poor compression	Wear of piston, cylinder and piston ring	Replace worn parts
		Air leakage of joint face between the cylinder body and the cylinder cover	Replace the cylinder pad
		Valve clearance is too large (too small)	Readjust
		Valve seal is not tight.	Repair

Compression pressure inspection

Remove the spark plug cap and the spark plug, and install the cylinder pressure gauge at the spark plug hole.

Pull the starter for several times and measure the compression pressure.

Atmospheric pressure in cylinder
($\geq 1.25\text{MPa}/1300\text{r}$)

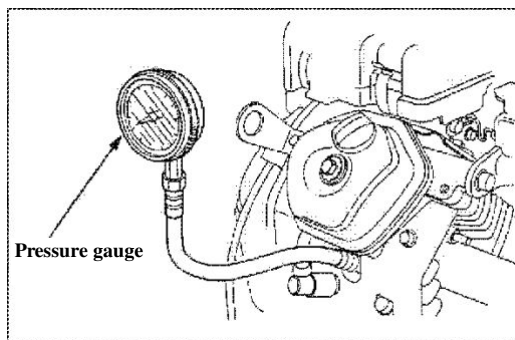

3-1-3 Unstable speed

Phenomenon	Cause	Remedy
There is knocking noise in the gasoline engine	Excessive wear of piston, cylinder and piston ring	Replace worn parts
	Excessive wear of piston pin and pin hole	Replace the piston or piston pin
	Excessive wear of small end of connecting rod	Replace the connecting rod
Deflagration	Gasoline engine overheating	Find the cause and eliminate
	There is carbon deposit in the combustion chamber.	Clear carbon deposit
	Unqualified gasoline	Replace with qualified gasoline
Misfire of gasoline engine	There is water in float chamber	Clean the float chamber
	Electrode clearance of spark plug is improper	Adjust electrode clearance
	Ignition coil failure, etc.	Check and replace damaged parts

3-1-4 Unable to ignite

Phenomenon	Cause	Remedy	
Unable to ignite	Fuel supply system	Fuel used up	Refuel
		Carburetor is clogged	Check oil way and dredge it
		Fuel leakage of float chamber	Repair float needle valve
		Needle valve is stuck	Disassemble the float chamber, and remedy the trouble
	Ignition system	Spark plug is broken through with carbon deposit and short circuit	Replace the spark plug
		The side electrode of the spark plug fell off	Replace the spark plug, and remove fallen object
		Falling-off of HV wire	Replace the HV pack
		Breakdown and short circuit of ignition coil	Replace the ignition coil
		Blow-out line is placed on the body	Find short circuit point and re-insulate
	Other	Severe cylinder scraping, falling-off of the valve	Repair and replace damaged parts

3-1-5 Overheating of general-purpose gasoline engine

Phenomenon	Cause	Remedy
Gasoline engine overheating	Insufficient oil	Fill sufficient oil
	Exhaust port is blocked	Clean exhaust port
	Leakage of air director	Repair damaged place
	Sundries blockage in the middle of cooling fins	Clean cooling fins
	Deformation of connecting rod causes the wears of the piston and cylinder liner edge	Replace the connecting rod
	Wears of cylinder, piston and piston ring causes air leakage between cylinder and crankcase	Replace worn parts
	Gasoline engine governor is improperly adjusted, causing the speed to be too high	Re-adjust the governor

3-1-6 Abnormal sound

Phenomenon	Cause	Remedy
Knocking noise	Wear of piston, cylinder and piston ring	Replace worn parts
	Wear of connecting rod, piston pin and pin hole	Replace worn parts
	Wear of main journal of crankshaft	Replace the bearing
	Piston ring is broken	Replace piston ring
	Too large valve clearance	Adjust the valve clearance
Metal knocking noise generates during deflagration	Excessive carbon deposit in combustion chamber	Clear carbon deposit
	Fuel label is incorrect	Replace fuel
	Gasoline engine overheating	Find the cause and eliminate
Other	The valve clearance is improperly adjusted	Re-adjust the valve clearance
	Loose connection between flywheel and crankshaft	Reassemble

3-1-7 Failure of power generation of the generator

Phenomenon	Cause	Remedy
The generator cannot generate electricity	The collecting ring and the carbon brush are contacted poorly	Clean the surface of the collecting ring and grind the arc surface of the carbon brush
	The brush spring pressure is abnormal	Replace the spring or carry out adjustment
	Stator and rotor output wires of the generator are contacted poorly The panel, instrument and power socket are contacted poorly	Check that the winding connector is reliable and the panel instrument and power socket are correct, or replace the defective parts.
	Loss of excitation	Carry out charging
	Check each winding for grounding or breakdown	Check and insulate them one by one.
	Check the main winding and the excitation circuit of the stator for open circuit.	Check and connect the open circuit section by section.
	AVR fault	Replace AVR

3-2 Pre-maintenance preparations

3-2-1 Safety factors

▲ WARNING Failure of observing the following precautions will cause the void of warranty commitment provided with the engine, and it may damage the engine or cause personal injury. Therefore, before operating the engine, the user shall pay special attention to following points:

- 1) Strictly carry out the matching according to power shown on the nameplate. It is strictly forbidden to operate under overload and over-speed or low speed for a long term.
- 2) Apply fuel and oil with code designation, which must be fully precipitated and filtered before use. Refueling appliance shall be maintained clean, and the oil shall be replaced regularly.
- 3) Check the tightness of fastening bolts of the engine regularly, and tighten them in time.
- 4) Clean the air filter element regularly and replace it if necessary.
- 5) This engine is air-cooled gasoline engine, so the debris and dirt on cooling fins, air directors and other components shall be removed in time to ensure normal cooling of the gasoline engine.
- 6) The operator shall be familiar with the working principle and structure of the engine, and understand how to operate emergency shut-down and all control components. Adhere to regular maintenance and service, and eliminate the fault found in time, and prohibit continuous operation of the engine after the failure.
- 7) When operating, please make sure that the engine shall be at least one meter away from the building and other equipment, and maintain good ventilation. Do not place flammable materials (such as gasoline and matches) nearby the engine or close to the running engine to avoid fire.
- 8) Refuel at a well-ventilated place. The engine shall be shut down when refueling. Do not smoke or make naked flame or spark in the place where the engine is fueled or in fuel storage site.
- 9) Do not overfill the fuel tank to cause overflowing of fuel. If there is fuel spilling, it must be thoroughly removed, and the generator shall not be started until spilled fuel is volatilized.
- 10) Do not operate the engine in a confined place or poorly ventilated place.
- 11) When the engine is running and within a period of time after it is shut down, it is strictly forbidden to touch the muffler to avoid scalding. In order to avoid getting burnt or fire, the generator shall not be handled or stored until it cools down.
- 12) Safety warning label

Please read the warning label carefully before operating the engine; our company will not be liable for the personal injury or equipment damage caused by ignoring the warning label.

3-2-2 Special tools

Tool name	Application location·Remarks
Float height gauge	Inspection of oil level of the carburetor
Valve guide replacer	Disassembly and installation of valve guide
Outer seat ring assembler	Assembly of the ball bearing
Assembler handle	Installation of the handle on the assembler and installation of the bearing
Inner seat ring assembler	Assembly of the ball bearing and the timing gear
Diamond grinder 45°	Correction of intake and exhaust valve seat surface
Diamond grinder 32°	Correction of intake and exhaust valve seat surface
Flywheel puller	Disassembly of flywheel
Bearing puller	Disassembly of the ball bearing
Valve guide reamer	Finish reaming of inner diameter of valve guide

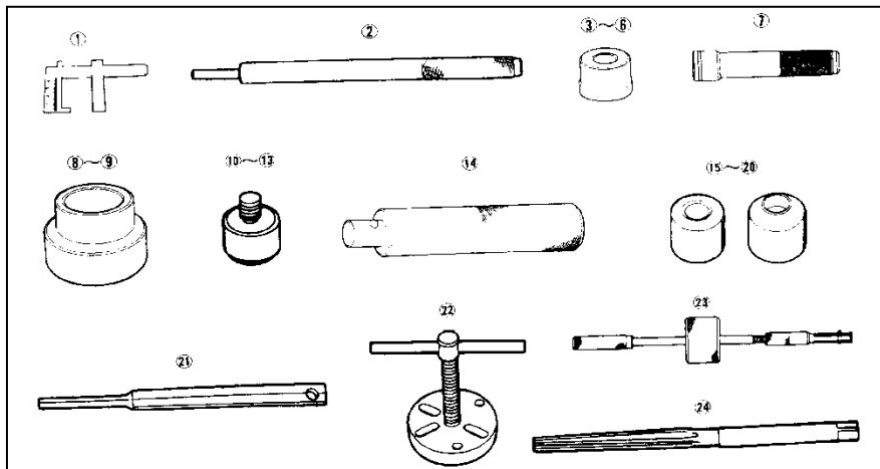

3-3 Disassembly chart

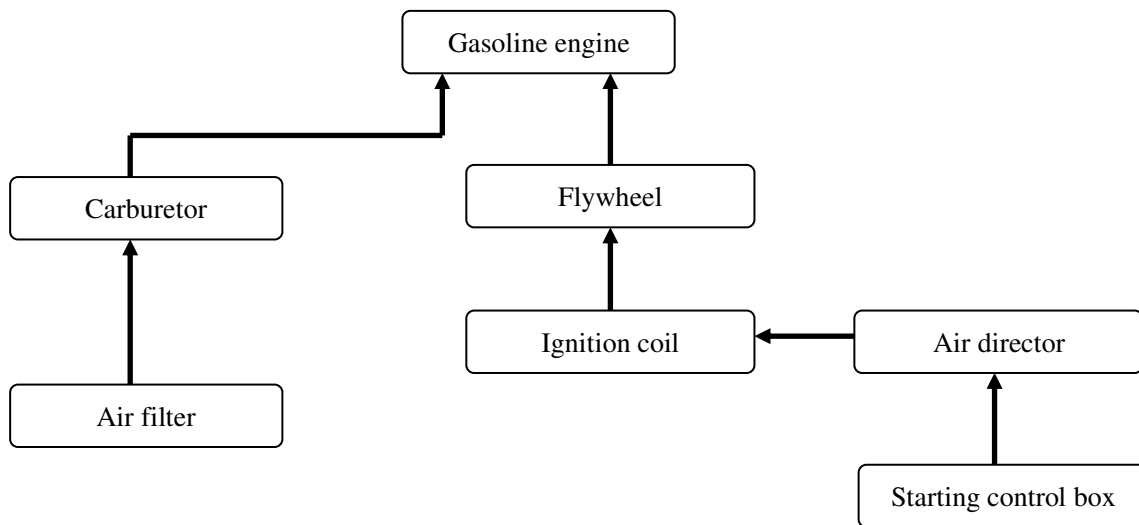

3-4 Gasoline engine

3-4-1 Air director

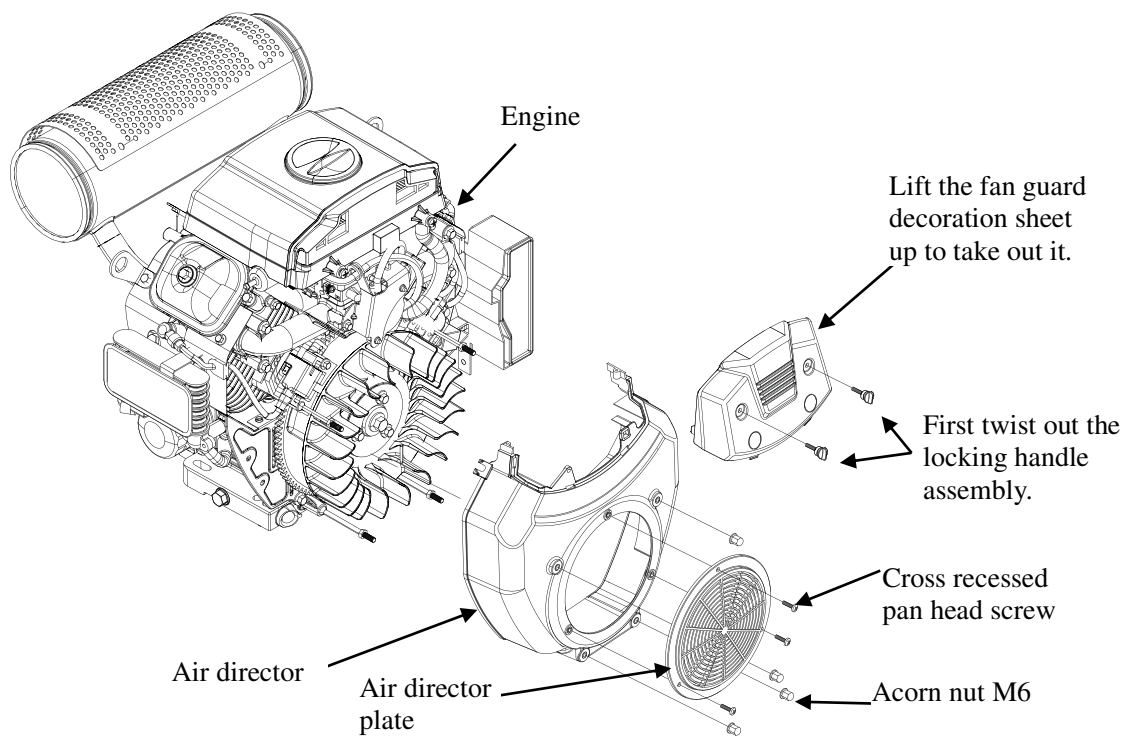

3-4-2 Impeller/flywheel/ignition coil/charging coil

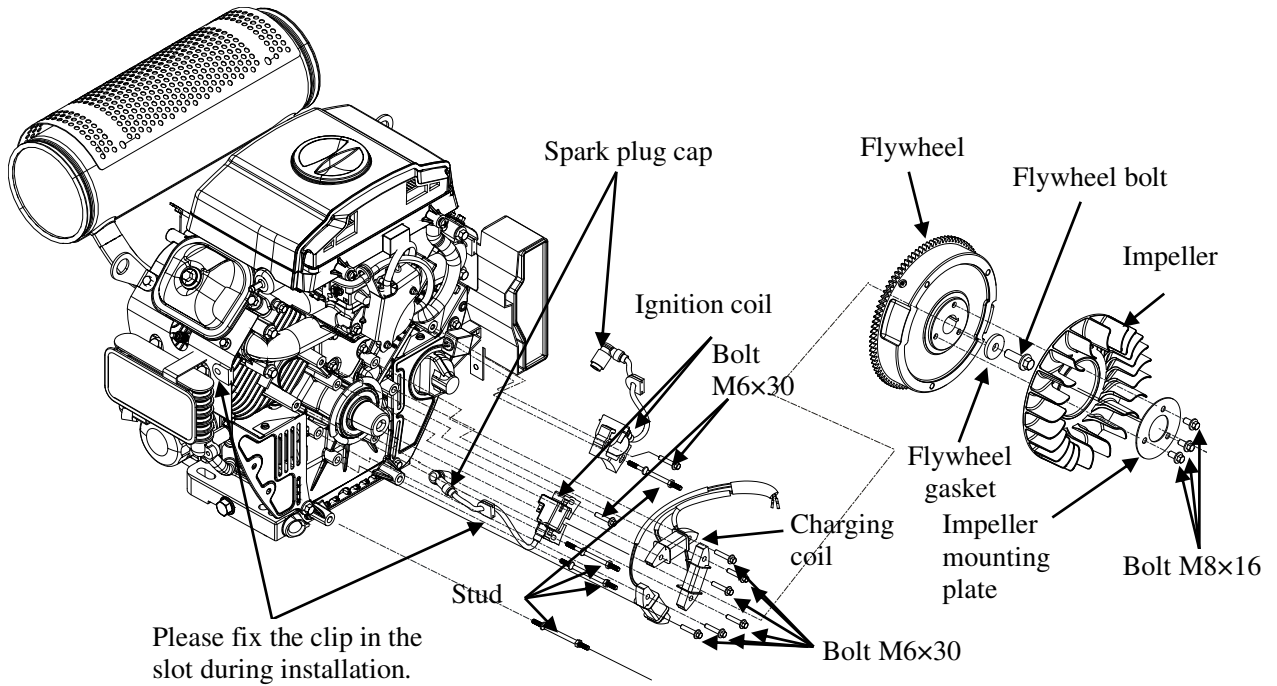

NOTICE Therefore, the parts in the figure are key components. Please tighten the bolts according to the torque table.

WARNING Too high torque will damage parts. Too low torque will result in unpredictable engine damage, and in severe cases, it may cause casualties.

1) Impeller

NOTICE Please align the lug behind the impeller with the hole on the flywheel during installation.

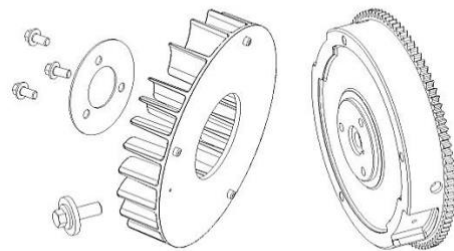

2) Flywheel

Remove the ignition coil and the charging coil before removing the flywheel.

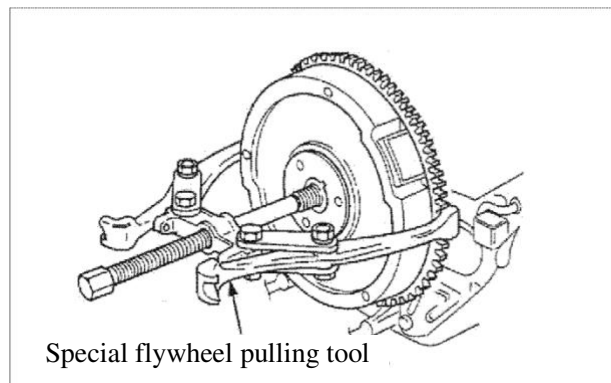

NOTICE

Use the special tools to remove the flywheel, and do not use the hard objects to knock it to avoid damaging the flywheel.

NOTICE

When the flywheel is removed, the semicircular key on the crankshaft may be brought out. Please check the existence of the semicircular key before installing the flywheel.

3) Ignition coil

a) Primary coil

Connect one ohm detection wire to the primary terminal of the ignition coil, and make the other detection wire contact with the iron core, and then measure the resistance of the primary coil.

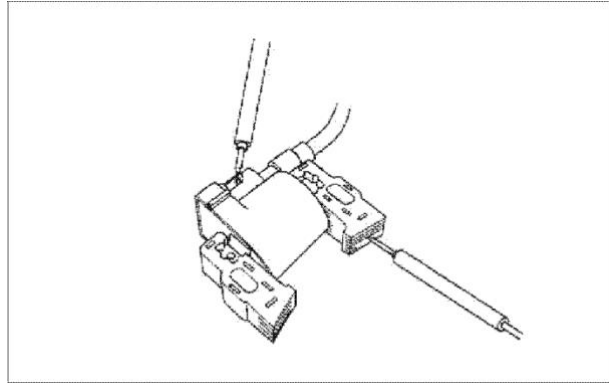

Resistance value on the primary coil side	1.46
---	------

b) Secondary coil

Remove the spark plug cap, connect one detection wire to the spark plug wire, make the other wire contact with the coil core, and then measure the resistance of the secondary coil.

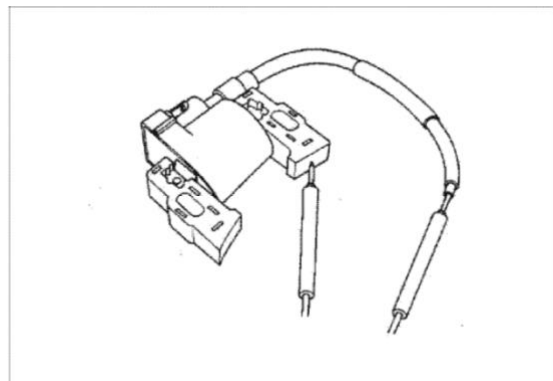

Resistance value on the secondary coil side	7.5
---	-----

Failure to remove the spark plug cap may lead to incorrect values.

c) Spark plug cap

① Resistance value

Connect one detection wire to the wire end of the spark plug cap, make the other detection wire contact with the spark plug end, and then measure the resistance of the spark plug cap.

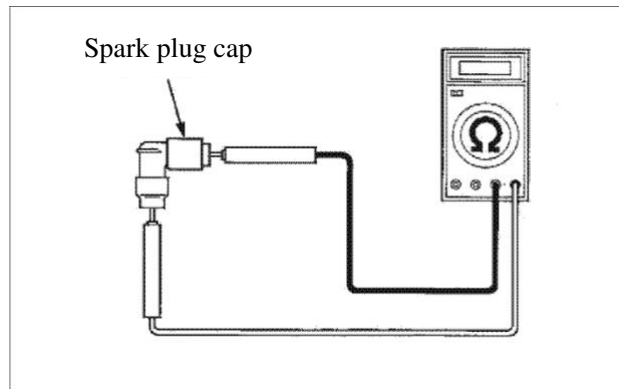

Resistance value	10KΩ
------------------	------

② Clearance

1. Unscrew the ignition coil bolt.
2. Insert a plug gauge between the ignition coil and the flywheel, and adjust the ignition coil position.
3. After adjustment, pre-tighten the bolt, check the clearance again, and then tighten the bolt and apply the torque if the clearance is correct.

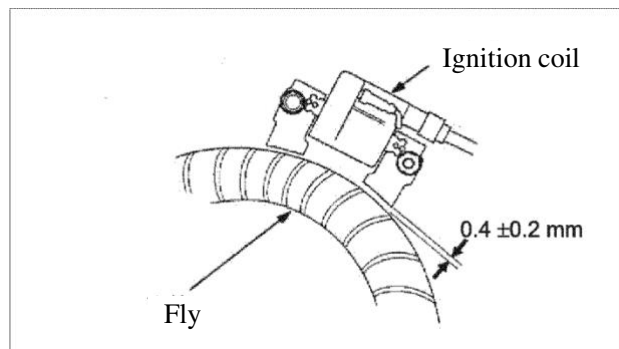

Clearance	0.4±0.05mm
-----------	------------

4) Charging coil

Connect the two ends of the multimeter to the two connectors of the charging coil, and measure the resistance of the charging coil.

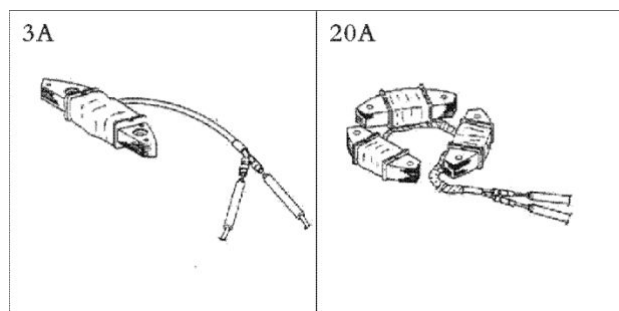

Resistance value	3A	
	20A	0.6Ω

3-4-3 Air filter

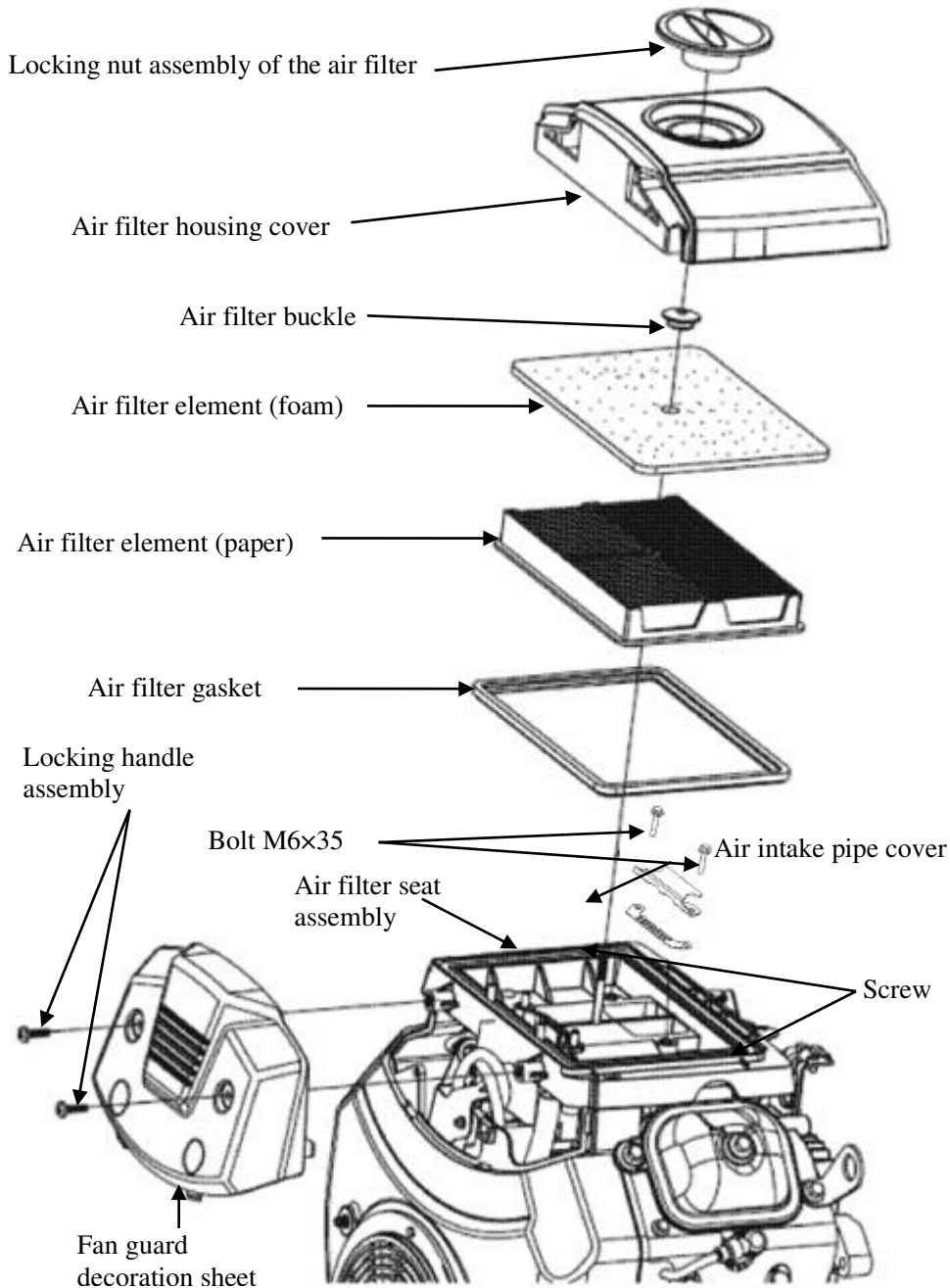

- 1) Remove the fan guard decoration sheet first. When removing the fan guard decoration sheet, lift it up and then pull it back.
- 2) Remove the air filter housing cover.
- 3) Remove the parts in turn from top to bottom.
- 4) To remove the air filter seat assembly, you should first twist out the screw.

▲ WARNING Be sure not to start the gasoline engine before the air filter is mounted, which will cause the gasoline engine to wear out quickly.

3-4-4 Gasoline pump and carburetor

NOTICE At high altitude areas, standardized carburetor will cause thick mixed gas, drop the output power and increase the fuel consumption rate for the gasoline engine. Gasoline engine used at high altitude area can be improved by assembling small-diameter main metering hole of the carburetor and re-adjusting adjustment screw of idle mixing ratio. If you often use the gasoline engine at the region of above 1,000 m,

you can go to authorized dealer of the Company to change the main metering hole and adjust the carburetor. Otherwise, the gasoline engine shall be used by reducing power.

Even if being equipped with proper carburetor, every 300 m's rise in ASL will reduce the power of the gasoline engine by about 3.5%. This reduction will be greater if it is not equipped with proper carburetor.

If a carburetor applicable to high ASL application is equipped to a gasoline engine for low ASL application, too thin mixed gas will cause the power reduction of gasoline engine, overheating and even cause more serious damage.

The gasoline is fed into the carburetor from the fuel tank and fuel filter. The fuel filter can filter out impurities mixed in the gasoline and oxides in the fuel tank. If the quality is defective, some impurities will enter the carburetor through the fuel filter. In addition, gasoline contains components capable of forming gelatinous substance, which will condense gelatinous substance after a long time of deposition to attach to components of the carburetor (such as main metering hole), oil way and the surface of float chamber. Air is fed into the carburetor by way of air filter. Based on the consideration that intake resistance shall not be too great and other factors, filter device shall not be too dense, hence some tiny impurities in air will still enter the carburetor via the air filter.

1) Gasoline pump

NOTICE

To remove the gasoline pump and the carburetor, please drain the gasoline in the oil pipe thoroughly first.

a) Remove the air filter and the fan guard decoration sheet (refer to maintaining the air filter)

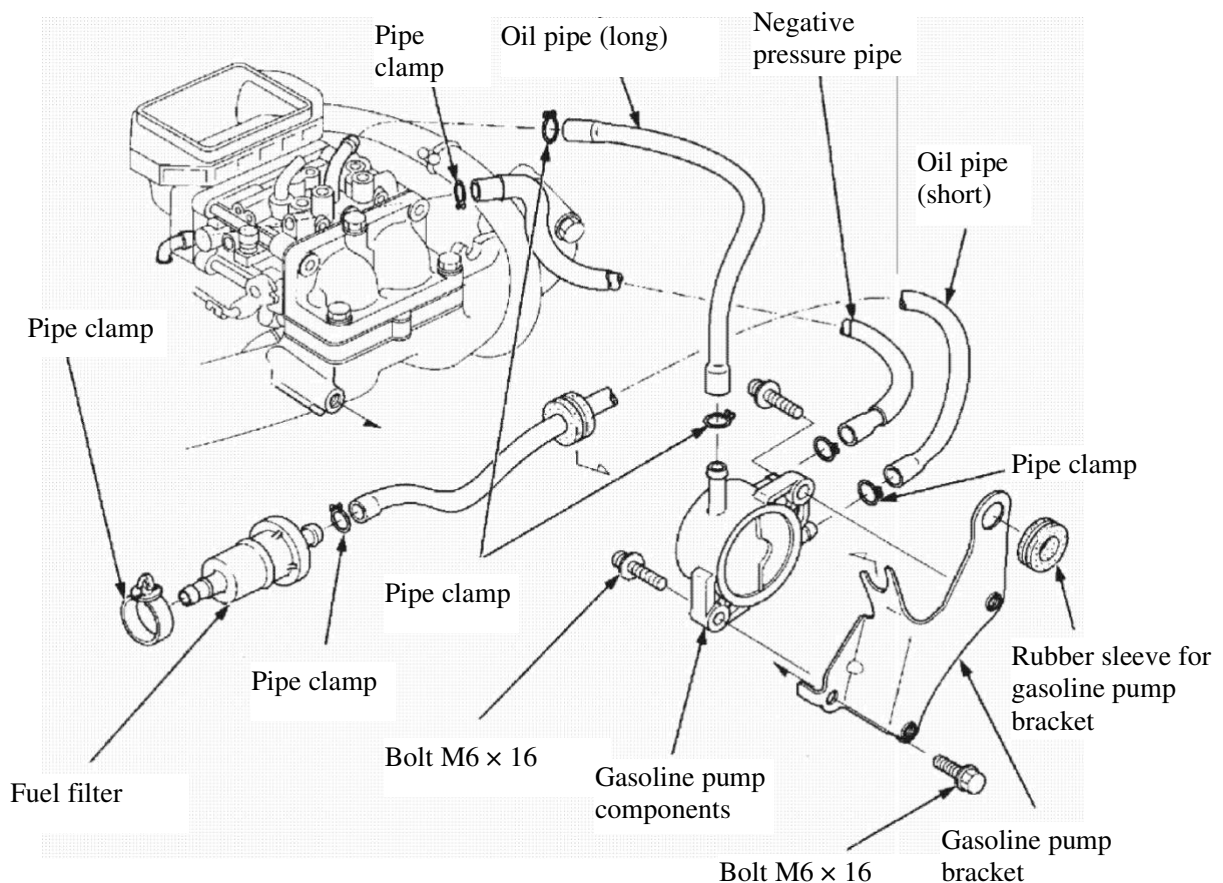

b) Carry out disassembly according to the above figure from right to left.

NOTICE

The oil pipe is vulnerable. So, please pay attention to inspecting it during disassembly and installation, and replace it immediately if it is damaged.

2) Carburetor

a) Disassembly and assembly

▲ WARNING If any part of the air filter is handled improperly, dirt will enter the air intake system and thus damage the engine.

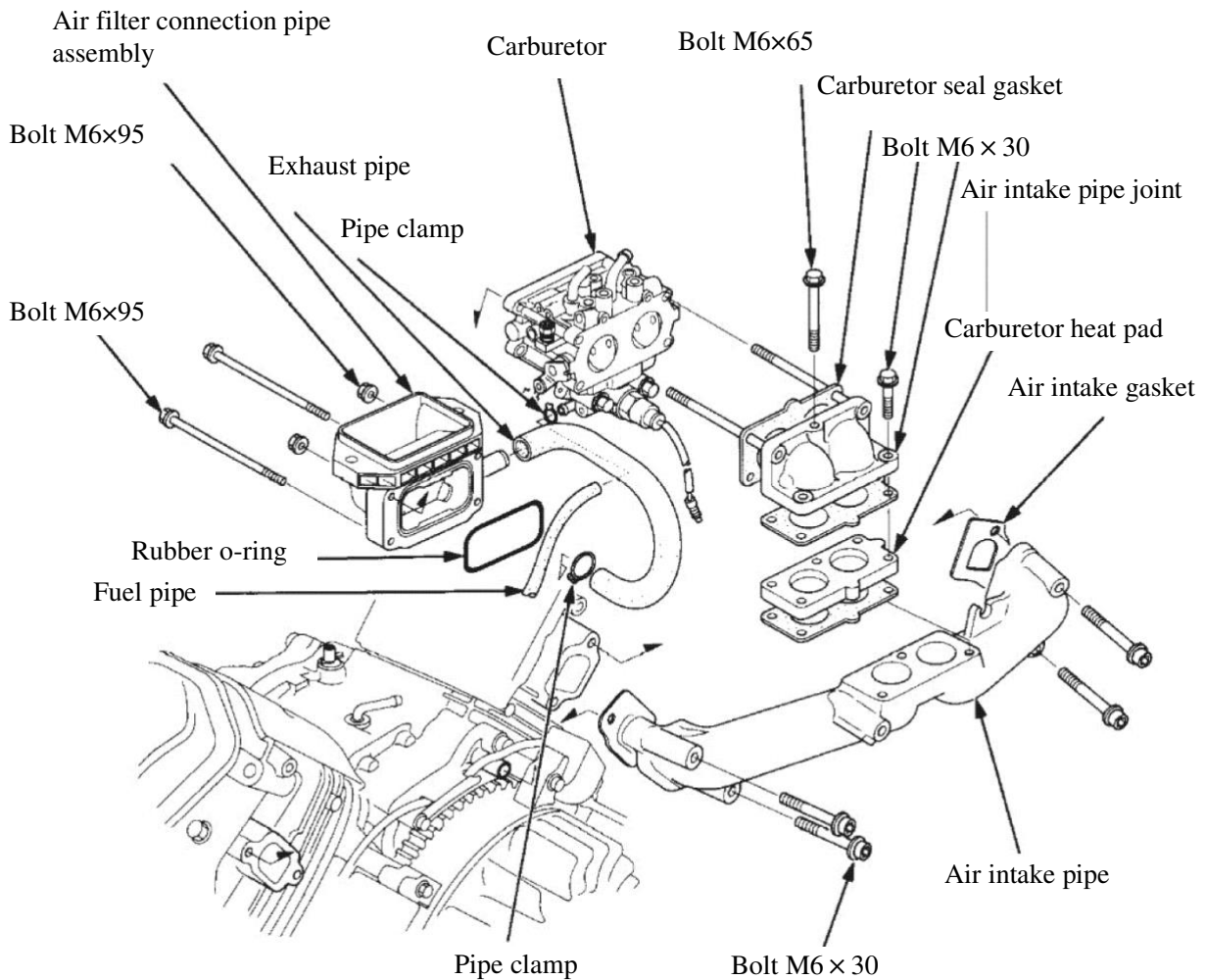

NOTICE

The oil pipe is vulnerable. So, please pay attention to inspecting it during disassembly and installation, and replace it immediately if it is damaged. In case of more bolts, please tighten the bolts according to the torque table.

b) Replacement of altitude kit

Disassembly and assembly of carburetor:

- ① Turn the carburetor upside down, and use a cross screwdriver to unscrew the 4 screws connecting the oil cup with the carburetor body in turn.

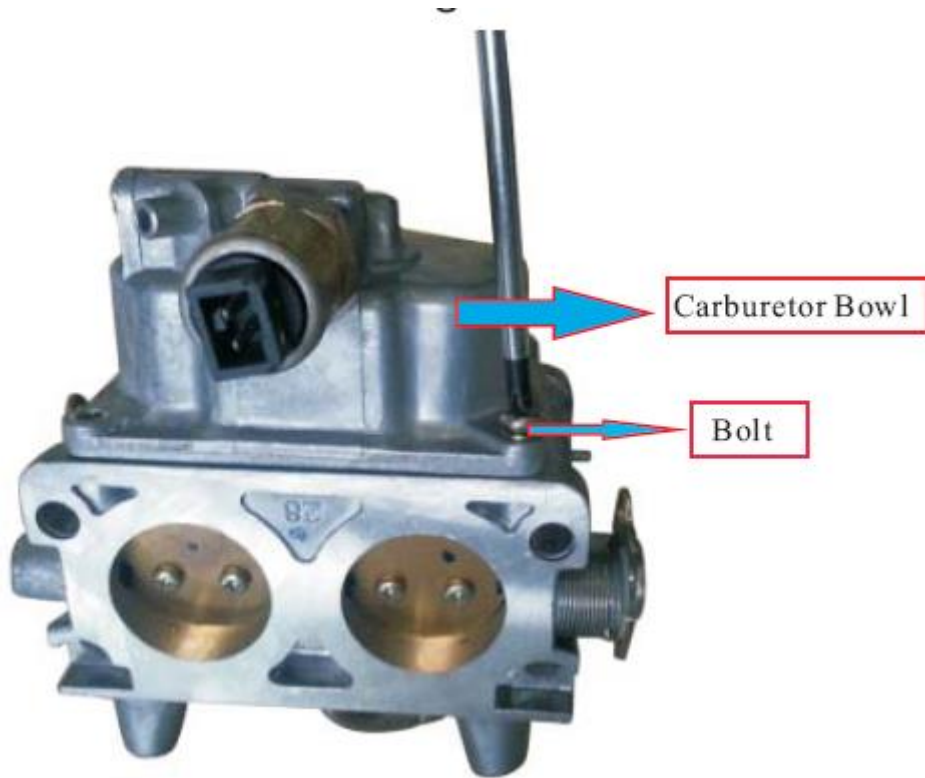

- ② Use the straight screwdriver to unscrew the main nozzle to the right.



NOTICE For replacement of main nozzles, both main nozzles should be replaced.

NOTICE When disassembling the main nozzles, please place the carburetor in the same direction as the above figure. Otherwise, the main metering hole may fall off.

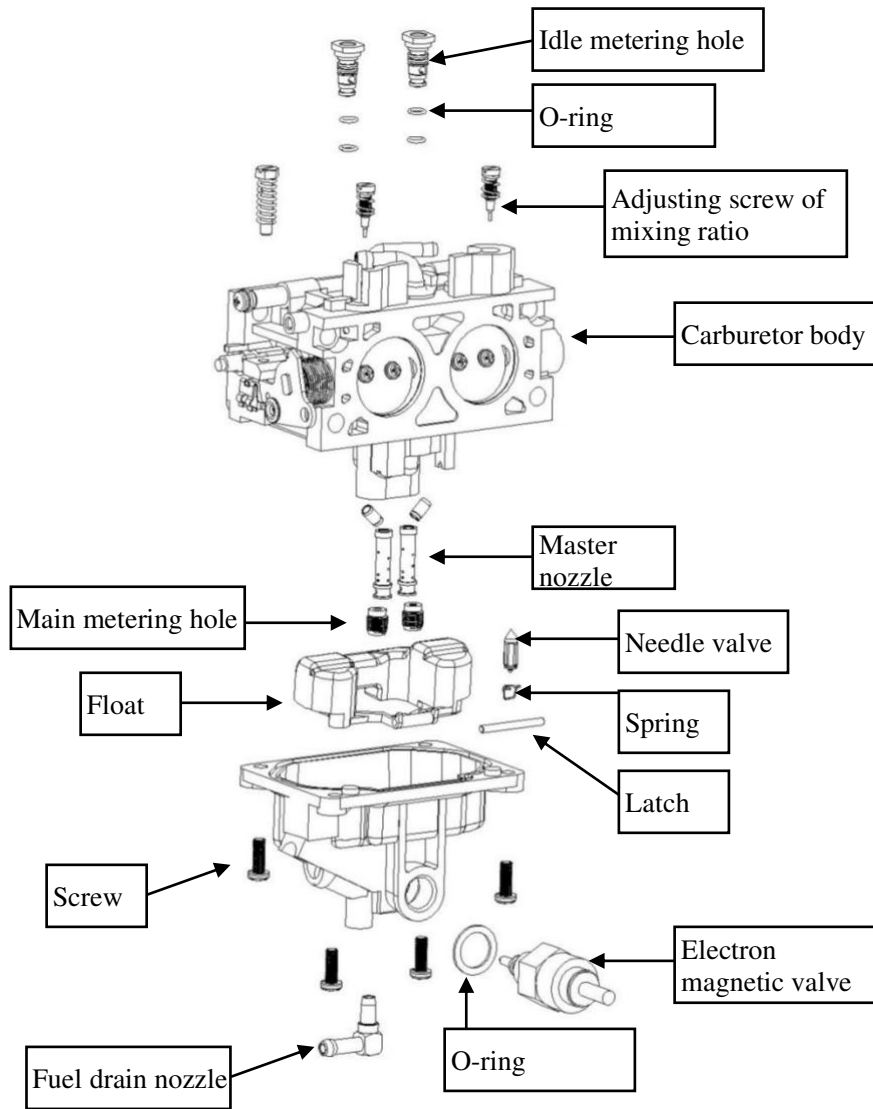

NOTICE

Before the installation of the carburetor, the fuel drain bolt must be unscrewed to drain off the fuel inside.

NOTICE

No Open Flames.

a) Before assembly, check the wear of the float valve, the float valve seat and the float spring.

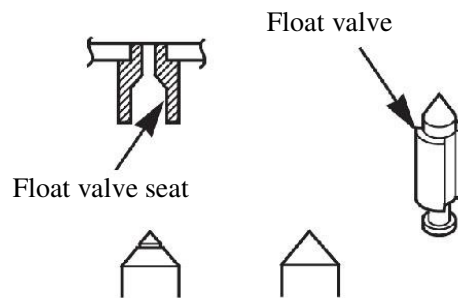

Damaged Normal

b) Clean thoroughly with compressed air before assembling.

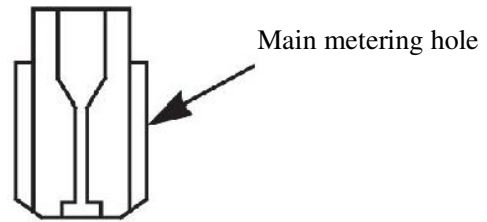

c) Clean thoroughly with compressed air before assembling.

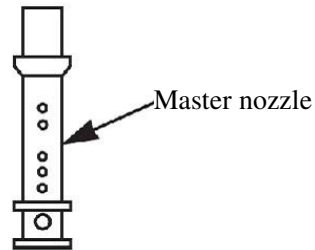

NOTICE Before assembly, please confirm whether the oil cup sealing washer exists.

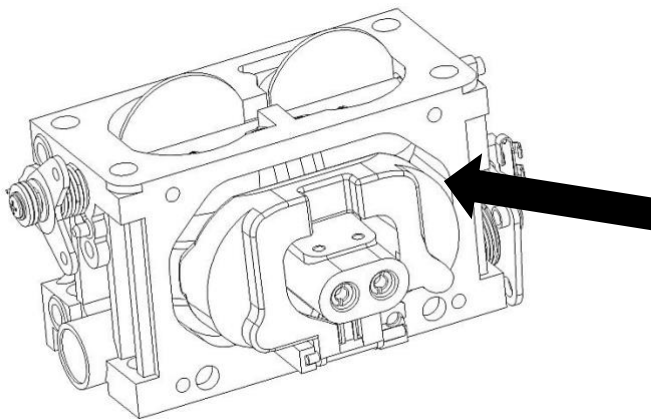

f) Inspection

Float height

Place the carburetor as shown in the figure. When the float valve just touches the float seat and the spring is not compressed, measure the distance between the top of the float valve and the carburetor body.

Specified float height	23mm
------------------------	------

In case of inconsistency between the actual float height with the specified value, please replace the float or the float valve and then reinspect the float height. (The figure below is for reference only. Please measure the relative position of the physical object)

Tool: float height gauge

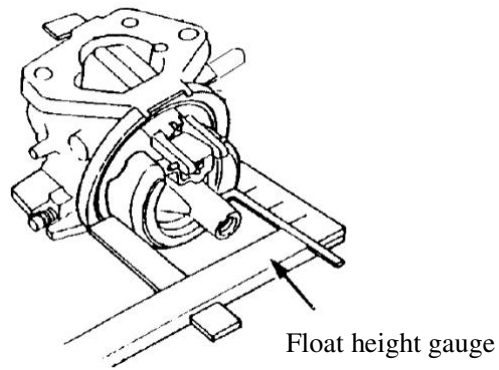

3-4-5 Cylinder head/valve

1) Disassembly/assembly

- ① Remove the air filter
- ② Remove the air director
- ③ Remove the carburetor and heat insulation pad

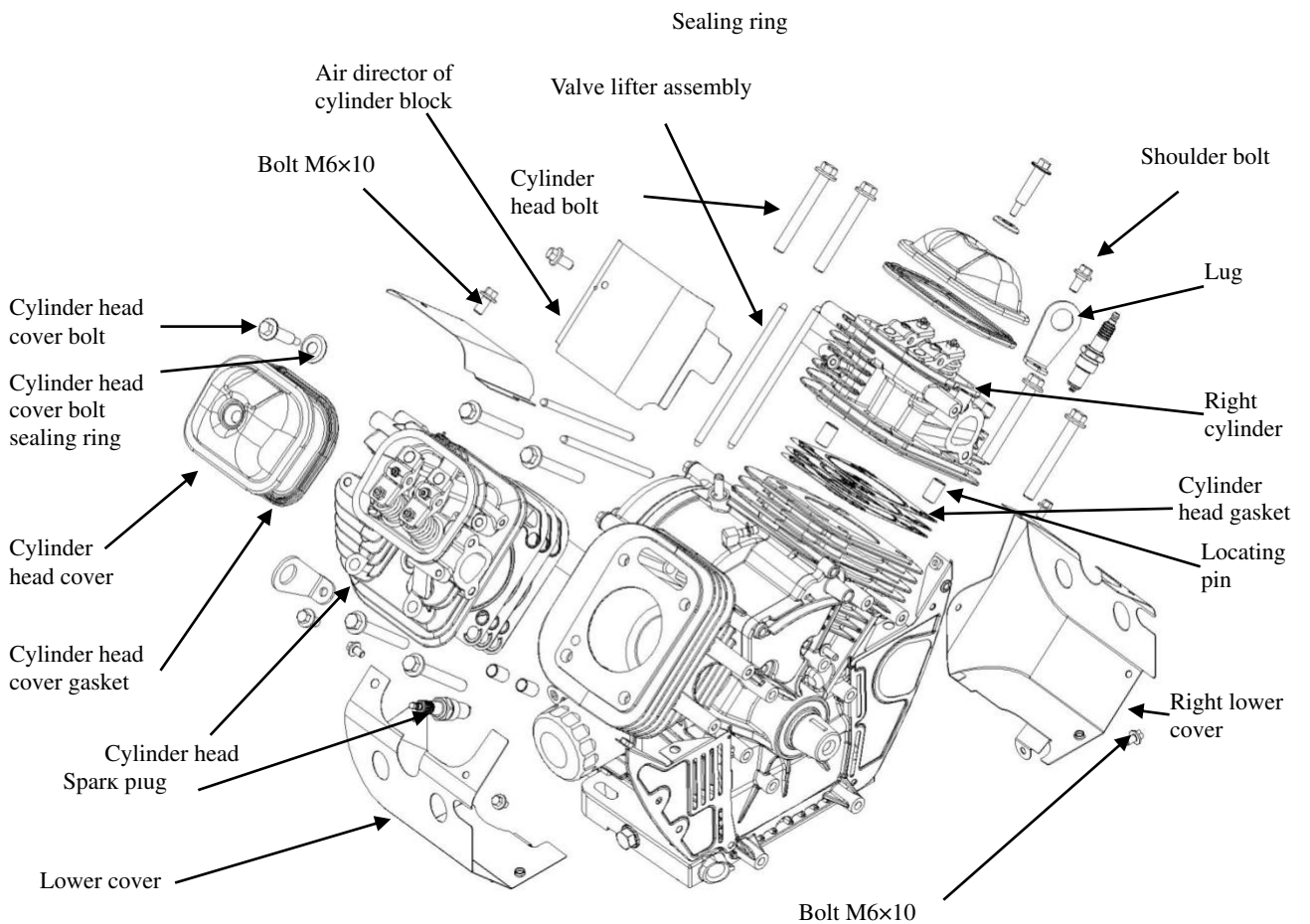

Carry out disassembly from top to bottom

2) Cylinder head

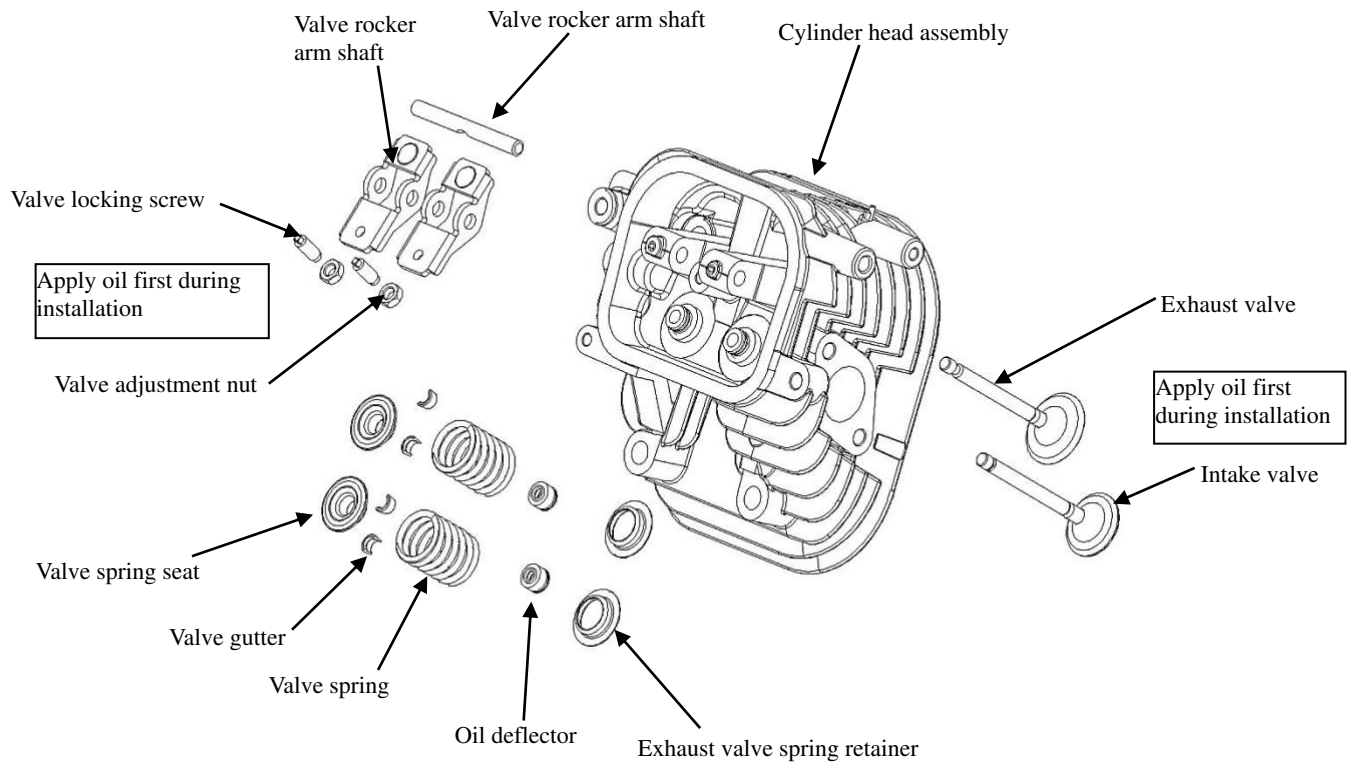

When disassembling the valve spring seat, press it down and then push the retainer up to take it out.

The bottom of the intake valve is marked IN and the bottom of the exhaust valve is marked EX. Please confirm it carefully before assembly. If the cylinder head is assembled on the cylinder, the spring retainer may fall into the cylinder, which should be noted.

NOTICE

3) Inspection/maintenance/adjustment:

① Valve spring retainer:

Move the front end of the valve stem longitudinally in the central hole of the spring retainer and remove it.

If the cylinder head is assembled on the cylinder, the spring retainer may fall into the crankcase, which should be noted.

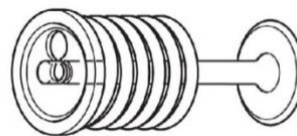

② Outer diameter of valve stem

Use a micrometer to check the outside diameter of valve stem. If the diameter is lower than standard or exceeds the maintenance limit, or the valve surface has visible ablation or cracks, replace it with a new valve.

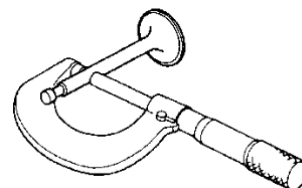

Standard		Maintenance limit	
5.48mm (intake)	5.54mm (exhaust)	5.318mm (intake)	5.275mm (exhaust)

③ Free length of valve spring

Measure free length of valve spring.

If it is below the standard or exceeds service limits, replace the spring.

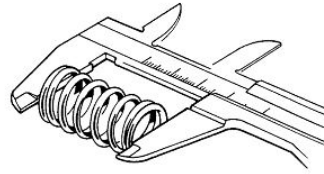

Standard	Maintenance limit
39.4mm	38mm

③ Valve guide

Inspection:

- Check if the inner surface of valve guide is smooth without scratches and scuffing; and if the fitting between valve guide and cylinder cover is solid.
- Before measuring the inner diameter of the valve guide pipe, remove carbon deposits inside valve guide pipe by valve guide reamer.

If the inner diameter of the valve guide pipe is below the standard or exceeds the maintenance limit, the guide pipe should be replaced.

Standard	Maintenance limit
6.515mm	6.562mm

Replacement:

- Put the valve guide to be replaced in the freezer of the refrigerator to freeze it for about 1 hour.
- Use the valve guide puller to remove the valve guide from the combustion chamber side.

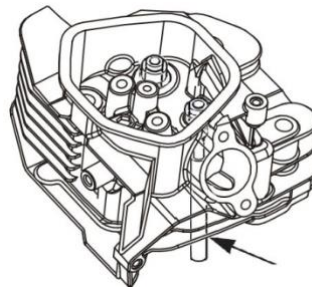

Valve guide puller

NOTICE

When removing the valve guide, be careful not to damage the cylinder head.

- Install the new valve guide from the valve spring side of the cylinder head.

Exhaust valve side: knock the exhaust valve guide until the retainer ring fully contacts the cylinder cover (as shown in the figure).

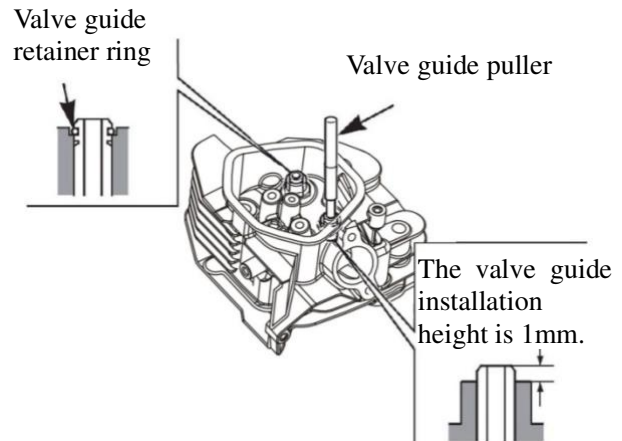

Intake valve side: knock the intake valve guide to the specified height (measured from the top of the valve guide to the surface of the cylinder cover) (as shown in the figure).

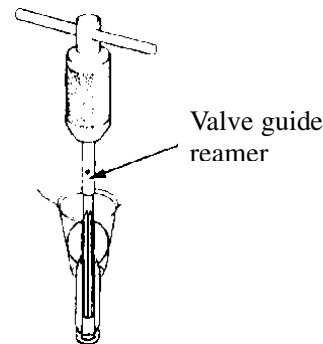

d) After installation, check whether the valve guide is damaged, and replace it if it is damaged.

Reamer:

When reaming precisely valve guide with a reamer, be sure to be at room temperature to get good result.

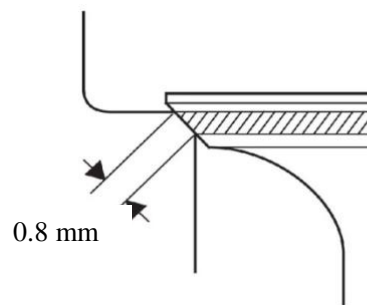

a) Apply a layer of cutting grease to the valve reamer and the valve guide.

Screw into the reamer clockwise until the reamer is fully screwed into the air valve guide pipe.

Continue to rotate clockwise to pull out the valve reamer from the valve guide.

Tool: valve guide reamer

b) Thoroughly remove dirt and debris from cylinder cover.

c) Inspect the hole of valve guide pipe, which shall be in the center of valve guide pipe and shall be straight and unobstructed, and insert the valve to inspect whether the action is smooth. If not, the valve guide may have been bent during assembly. If it is bent or damaged, replace the valve.

d) Check the clearance between the valve stem and the guide.

e) Clearance between the valve stem and the valve

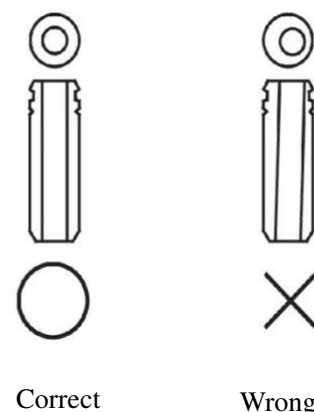

guide pipe: Subtract outer diameter of valve stem from corresponding inner diameter of valve guide pipe to obtain the clearance between valve guide pipe and valve stem.

f) If the clearance between valve stem and valve guide exceeds maintenance limit, replace a new guide, to judge if the clearance can be within maintenance limit. If so, replace valve guide and stick valve guide.

Re-trim valve seat when replacing the valve guide pipe.

④ Valve seat:

a) Thoroughly remove carbon deposit out of combustion chamber and valve seat, and apply a thin layer of red lead powder on the surface of valve, or other adhesive color paints easy to be wiped.

b) Insert the valve and press the valve with effort a few times, but do not rotate the valve on the valve seat. If the valve seat is stained with paint, it indicates that it is in close contact with the valve; otherwise, it fails to contact.

This indicates that the valve and the valve seat are not concentric.

c) Grind the valve seat by 45° grinder to create a smooth valve seat being concentric with the valve guide, and rotate it clockwise (do not rotate it counterclockwise).

Tool:

Valve grinder

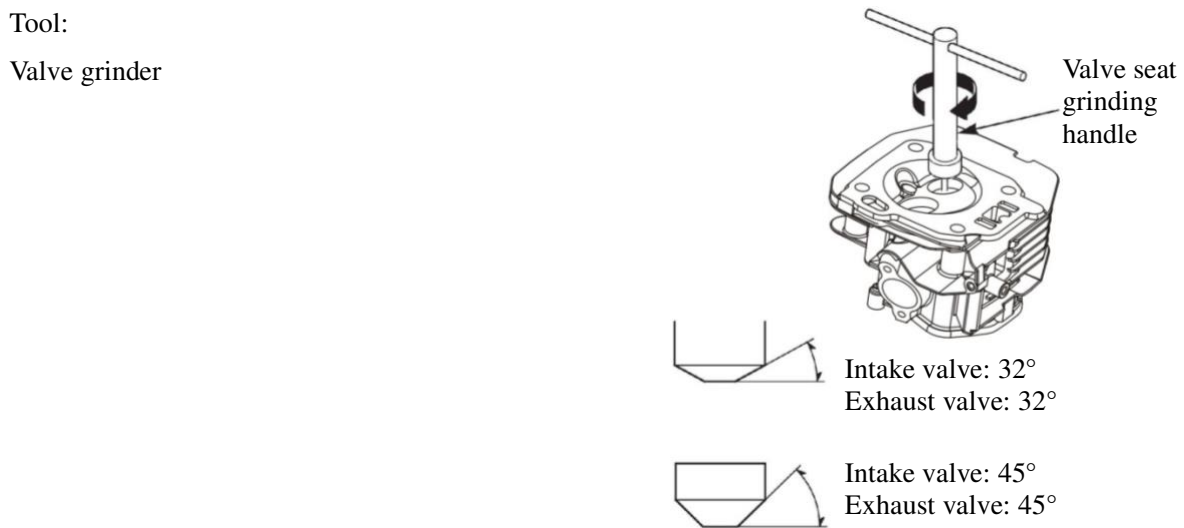
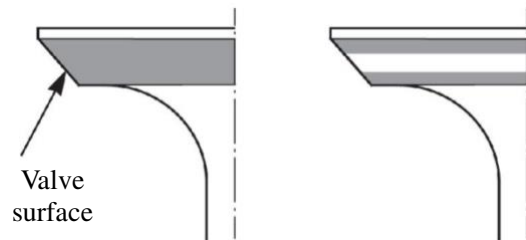

d) Use 32° and 45° grinders to reduce and adjust the valve seat, to make it be in contact with middle part of valve cone face.

Grind top edge of valve seat by 32° grinder (contacting too high).

Grind bottom edge of the valve by 45° grinder (contacting too low).

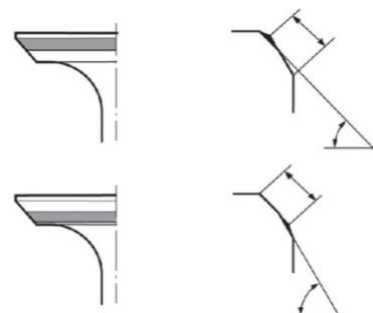

Make sure that the contact width of valve seat completed is within specified range.

Standard	Maintenance limit
0.85mm	2.0mm

e) Slightly grind by 45° grinder to remove any burr on the edge of valve seat.

f) After reshaping the valve seat, check the width of valve seat. Use only the colorant on valve cone face, insert the valve and press the valve several times with effort, but ensure that the valve does not rotate on the valve seat. If the valve seat cone face is evenly stained with colorant, as shown in the figure, it means that the valve is in good contact with the valve seat cone face.

g) Apply abrasive to valve seat cone surface, and rotate valve grinding tool to grind the valve seat.

h) Check valve clearance after assembly.

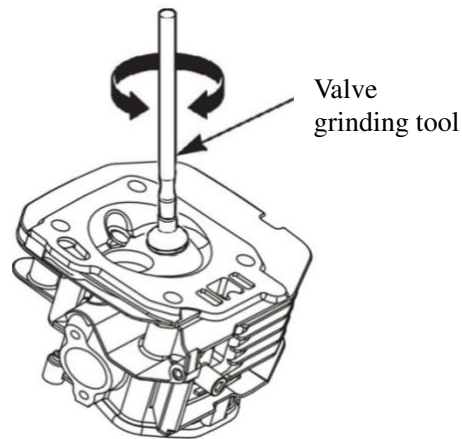

3-4-6 Muffler

The muffler will get heat. Please keep this gasoline engine out of reach of passersby and children.

- During the operation of the gasoline engine, any combustible goods shall not be placed near the exhaust port.

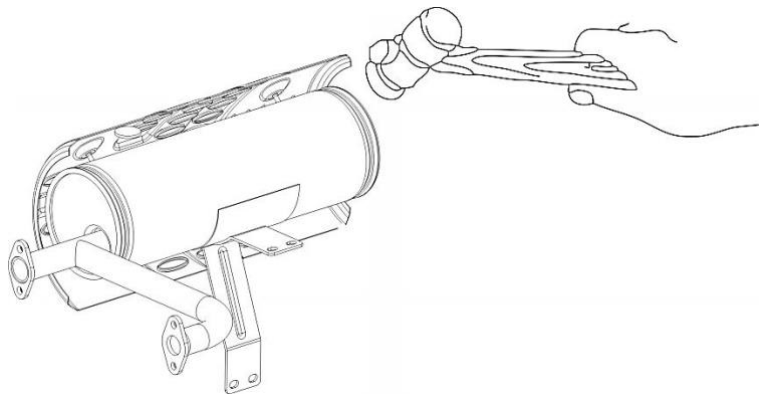

After removing the muffler, knock it with a clinker hammer for decarburization.

Don't clean it with iron wire, or the sound proofing material might fall off, which will reduce the silencing performance.

The muffler sealing gasket can't be reused.

Disassembly and assembly

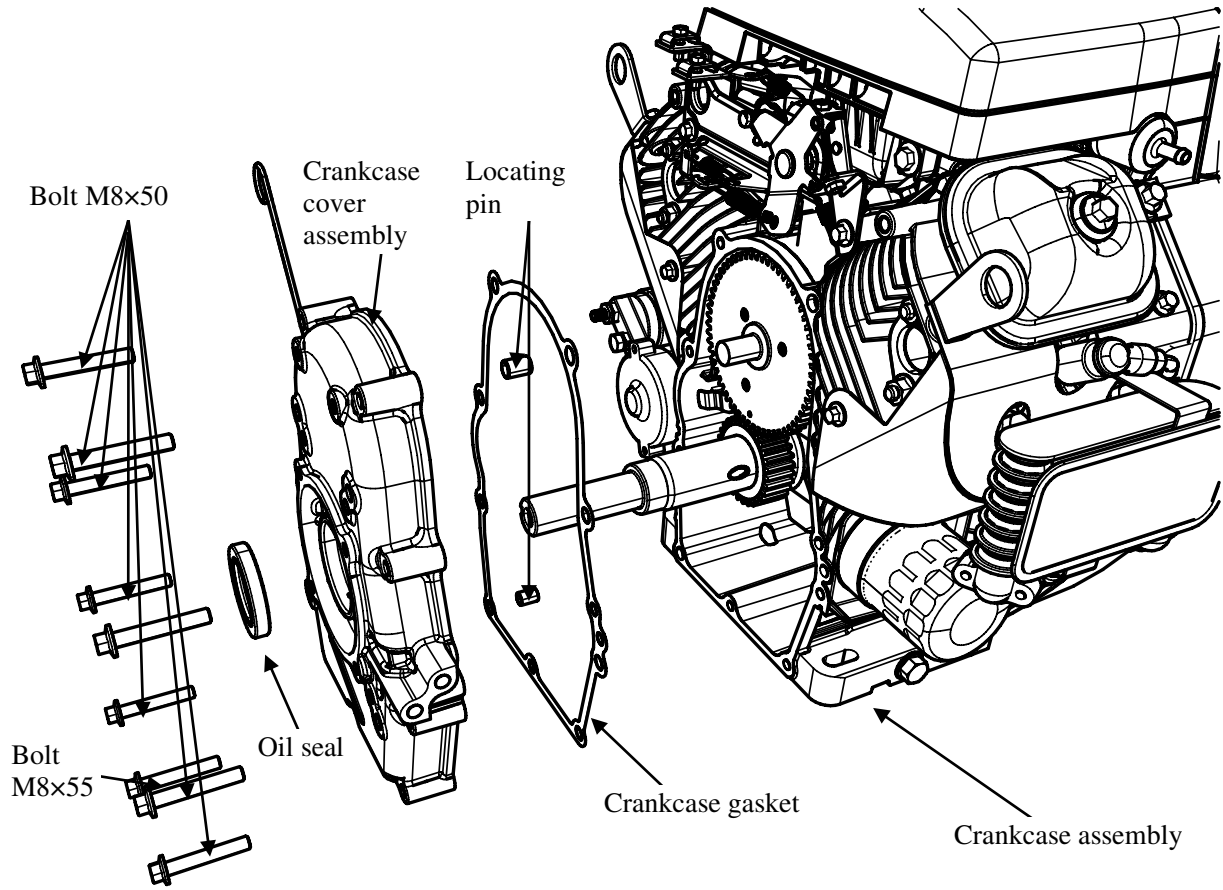

2) Crankcase cover assembly

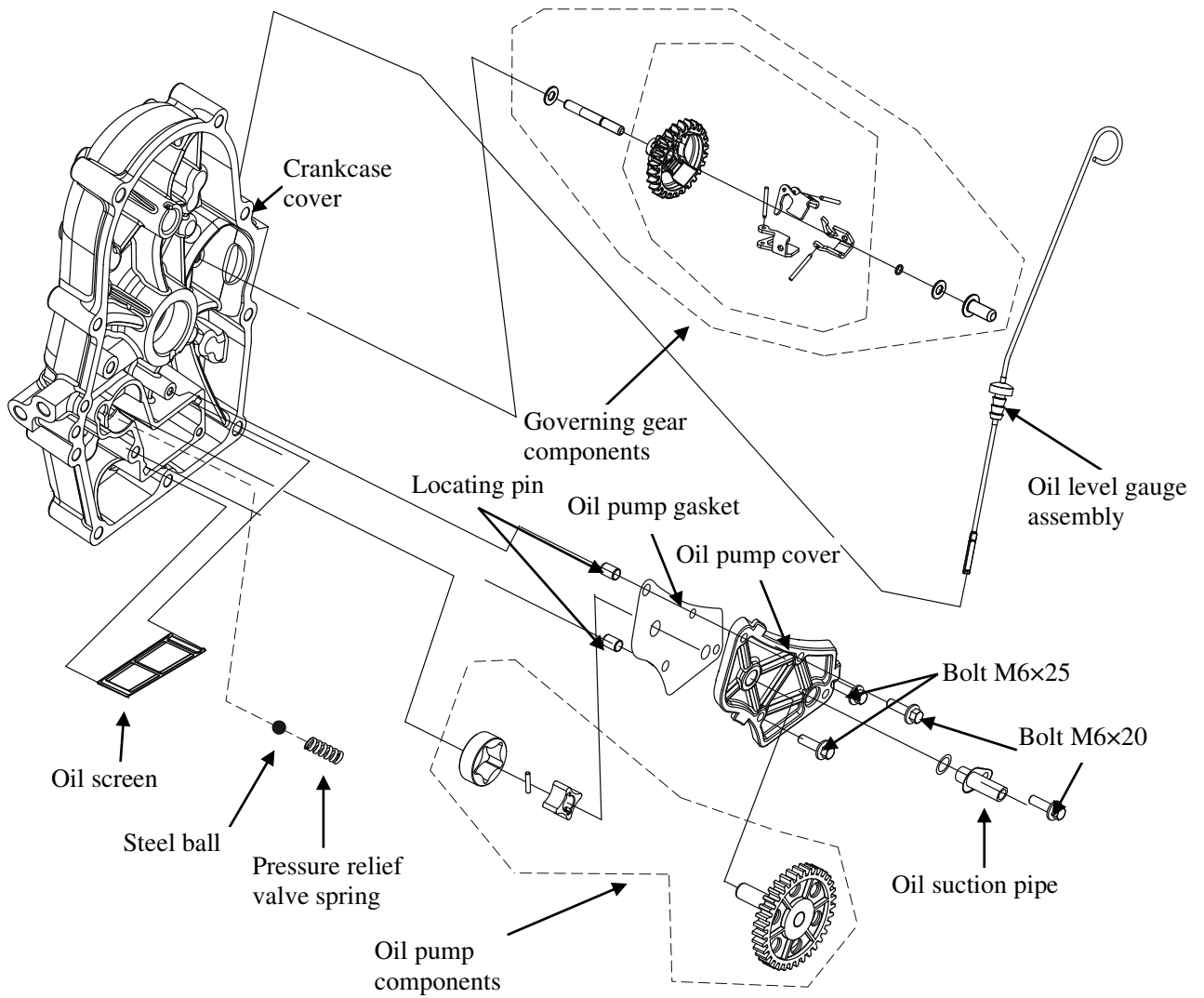

3) Crankcase assembly

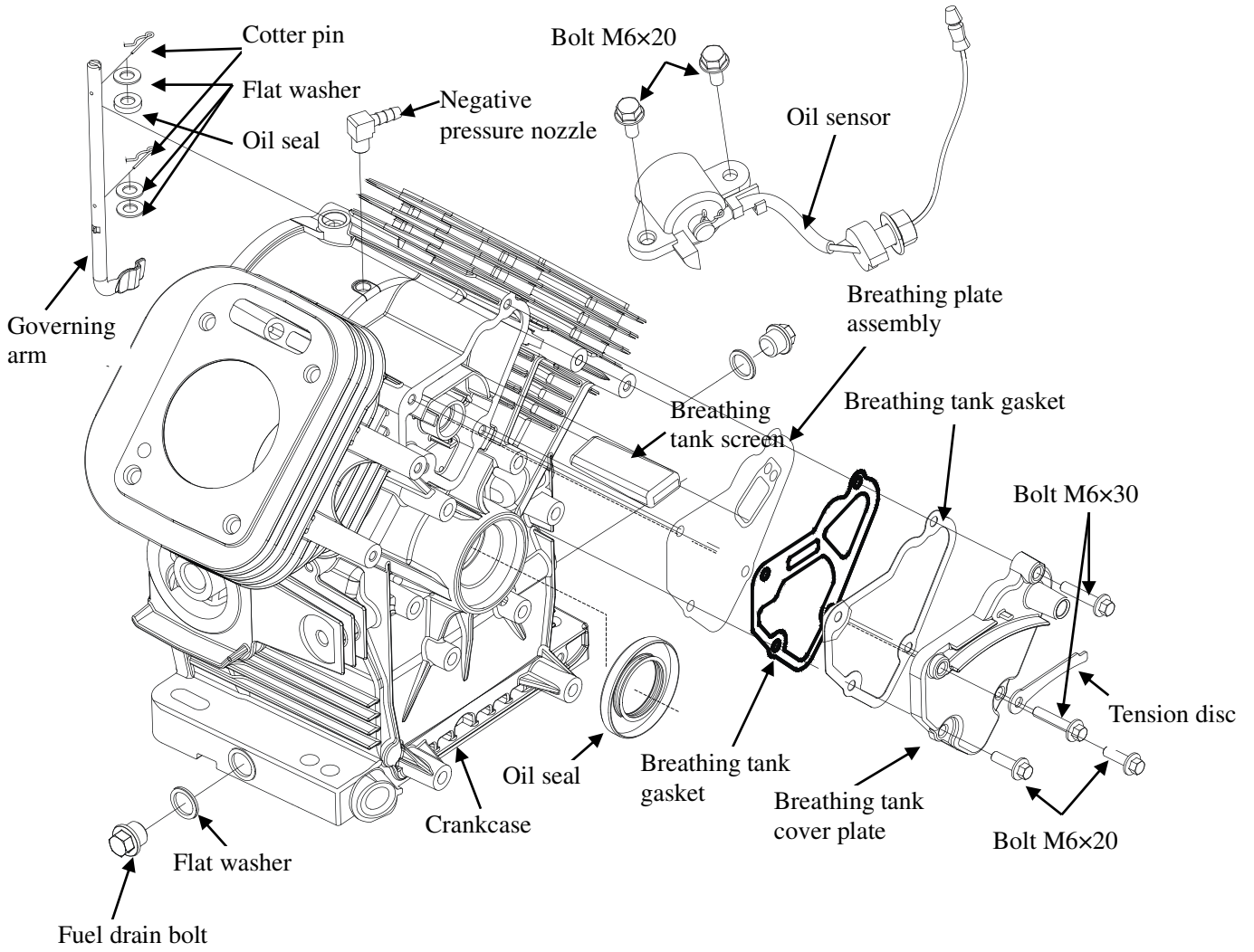

4) Crankshaft/piston

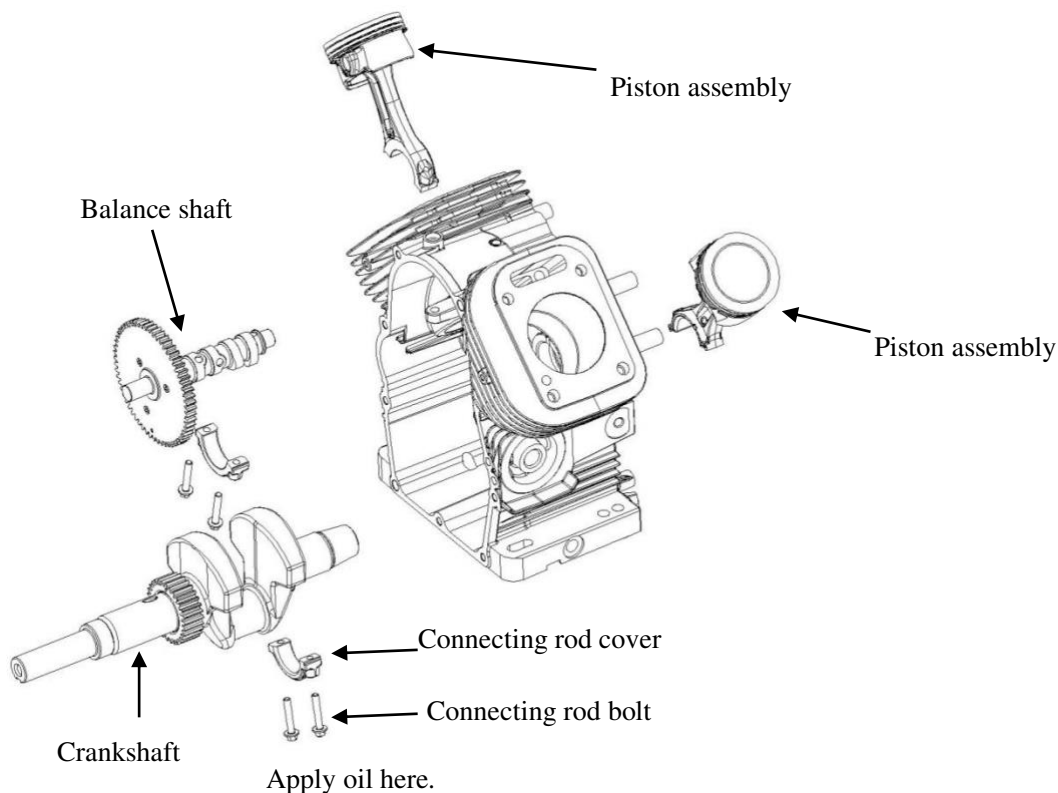

① Installation

a) Piston

Make manufacturer's mark face up when assembling. Be careful not to confuse the ring 1 with the ring 2 (the ring 1 is chrome plated).

Make sure that piston ring moves freely after assembling.

Make openings of various piston rings keep away from the direction of piston pin and scatter by 120 °.

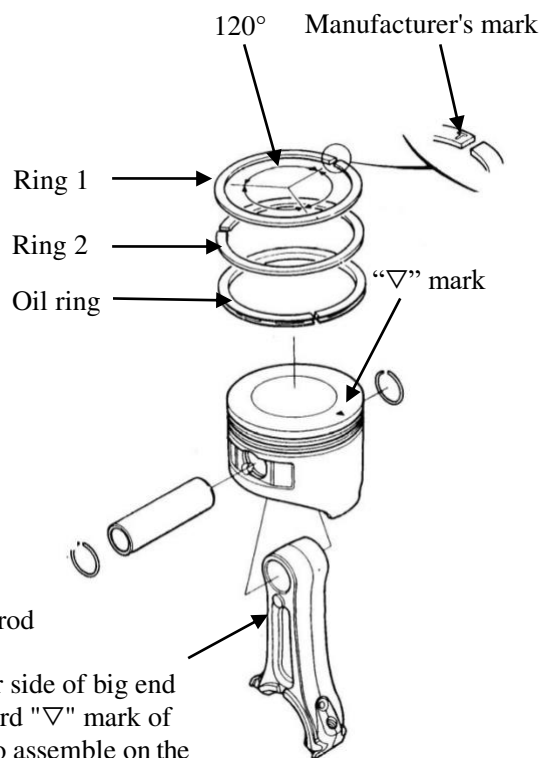

Connecting rod Assembly:
Make longer side of big end part be toward "▽" mark of the piston, to assemble on the piston.

b) Snap ring of piston pin

Jack the front end at the piston groove, to clamp the other end with a nose plier, and mount it in the groove while turning.

Make the opening of snap ring be away from the notch of piston.

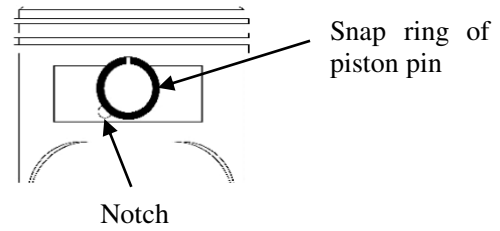

c) Connecting rod cover

Align connecting rod with the edge of the connecting rod cover when assembling.

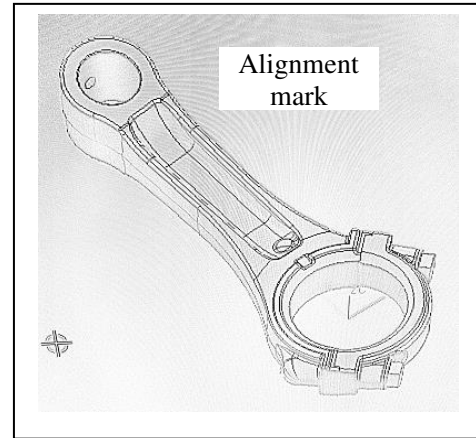

② Piston inspection

Inspect the contact between the piston and cylinder, ring groove defect, top ablation and cracking, etc. If it is seriously damaged, such as broken, it shall be replaced.

Remove carbon deposits

Carbon deposit is accumulated on the top of piston and the edge of upper port of the cylinder. Carbon deposits shall be cleared up before the inspection. Soak the carbon deposit with kerosene first, and then remove it with a blunt scraper or metal brush.

a) Outer diameter of piston skirt

Measure the outer diameter of the piston skirt by outer diameter micrometer, to replace it if it exceeds the service limit.

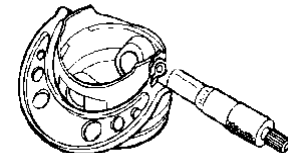

Standard	Service limit
81.962mm	81.86mm

b) The clearance between piston pin hole and piston pin

Use the inside micrometer and the outside micrometer to measure the inner diameter of the piston pin seat hole and the outer diameter of the piston pin respectively. And then calculate its clearance value based on measured result.

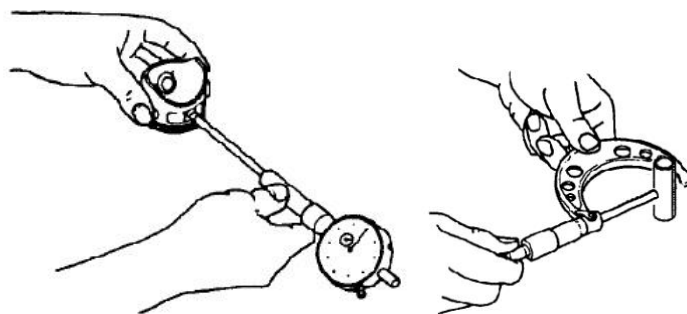

Standard	Service limit
16.992mm	16.954mm

c) Piston-cylinder clearance

The difference between the maximum diameter of the cylinder and the diameter of the piston skirt is the piston-cylinder clearance.

NOTICE

This clearance must be inspected before and after repair.

During inspection, put the piston upside down in the cylinder, put a thickness gauge with appropriate thickness between the pressure bearing surface of the piston skirt and the cylinder wall, and then pull out the thickness gauge. If you feel some resistance, but you can pull it out smoothly, the thickness of the gauge at this time is the clearance between the cylinder and the piston.

Standard	Service limit
0.015-0.05mm	0.12mm

d) Clearance of piston ring side

During inspection, place each ring in its respective piston ring groove. Piston rings shall rotate freely, to be neither loose nor sluggish. Then measure by inserting a thickness gauge into the clearance between upper and lower planes of the ring and slot.

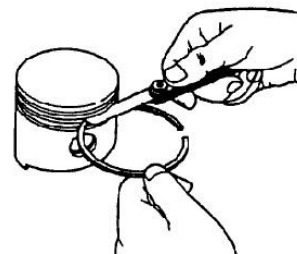

Standard	Service limit
0.015-0.045mm	0.15mm

e) Piston ring closing clearance

Put piston ring horizontally into the cylinder, push the ring to working position with piston head, and then measure its opening clearance by thickness gauge. This clearance shall be neither too great, nor too small. Too great clearance may make cylinder sealing performance get bad, while, too small clearance will cause the piston ring to be stuck in the cylinder due to thermal expansion during operation, causing piston ring breaking or even "cylinder scraping". Ring opening clearance is small, the opening can be filed by thin flat file. It shall be placed into the cylinder for

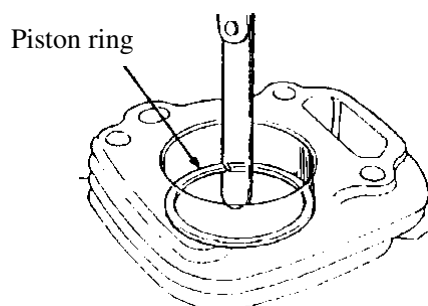

inspection while filing, until the clearance is proper.

Standard		Service limit
Ring 1/ring 2	0.20-0.40mm	1.0mm
Oil ring	0.15-0.35mm	1.0mm

③ Inspection of connecting rod

When the connecting rod is bent, twisted, or the outer ring of the big end bearing pad and the small end bushing moves, or there is a crack on one side, it shall be scrapped and replaced with new one.

a) Inspection of inner diameter of small end

If it is below the criterion or exceeds the maintenance limit, the connecting rod should be replaced.

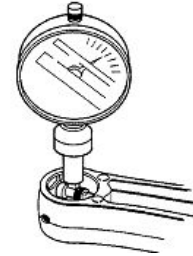

Standard	Service limit
17.016mm	17.052mm

b) Inspection of inner diameter of big end

If it is below the criterion or exceeds the maintenance limit, the connecting rod should be replaced.

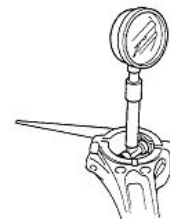

Standard	Service limit
40.022mm	40.066mm

④ Inspection of camshaft

The camshaft is main driving part of valve train of gasoline engine, which controls intake and exhaust valves to open or close.

Its structural feature is: On the shaft, there are the cam and supporting journal meeting the requirements for controlling air intake and exhaust. When the cam is working, it bears the periodic impact load, and the cam working surface and the tappet have intense friction, which is easy to wear or scratch. Therefore, the cam is required to have wear resistance and good lubricity.

Visually inspect cam surface and cam height for damage, and the camshaft and bearing for being loose or worn, and if so, replace the whole group.

Inspect the height dimension of the cam. When the dimension of cam height is less than the service limit, replace the camshaft.

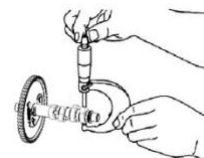

Standard		Maintenance limit
Cam height Intake	4.723mm	4.35mm

Cam height Exhaust	4.723mm	4.35mm
--------------------	---------	--------

Inspect the outer diameter of the camshaft journal.
When it is less than the service limit, the camshaft should be replaced.

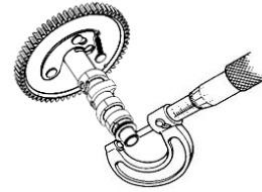

Standard	Maintenance limit
16mm	15.916mm

Analysis on causes of camshaft wear and its impact on the performance of whole gasoline engine:

The main cause for abnormal camshaft wear of the camshaft is poor lubrication, Factors such as low oil viscosity, many impurities and small circulating oil volume is unable to form complete oil film on the camshaft surface, to cause it to be in a state of high-speed dry friction, resulting in serious wear on the cam surface. The second is assembly accuracy of the camshaft. When matching clearance between camshaft journal and camshaft seat or bearing is out of tolerance, rotation accuracy of the camshaft will decrease, and the contact with related parts will generate deviation plane t cause abnormal wear.

⑤ Timing gear

Inspect meshing clearance of the timing gear, which shall align marks of gears on both sides.

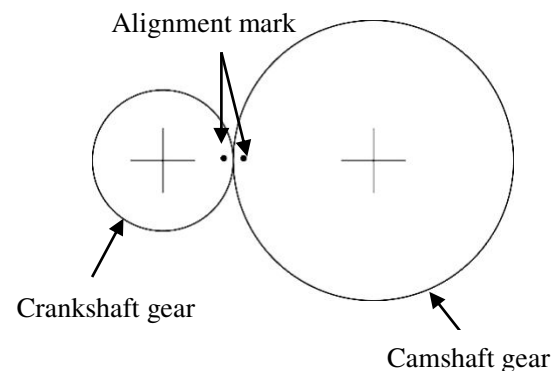

The main damage of timing gear is the wear of gear tooth, tooth face peeling or roughness, gear deflection, gear tooth breakage, etc. Due to the wear of gear teeth, the greater the meshing clearance is, the greater the noise will be.

If gear face of timing tooth is bruised or damaged or rupture angle, it shall be replaced with a new one for any case.

NOTICE

When replacing new parts, it is better to replace the whole part to ensure that there is a more consistent meshing surface.

3-4-7 Starting control box

a. Disassembly and assembly

(Automatic starter specification only)

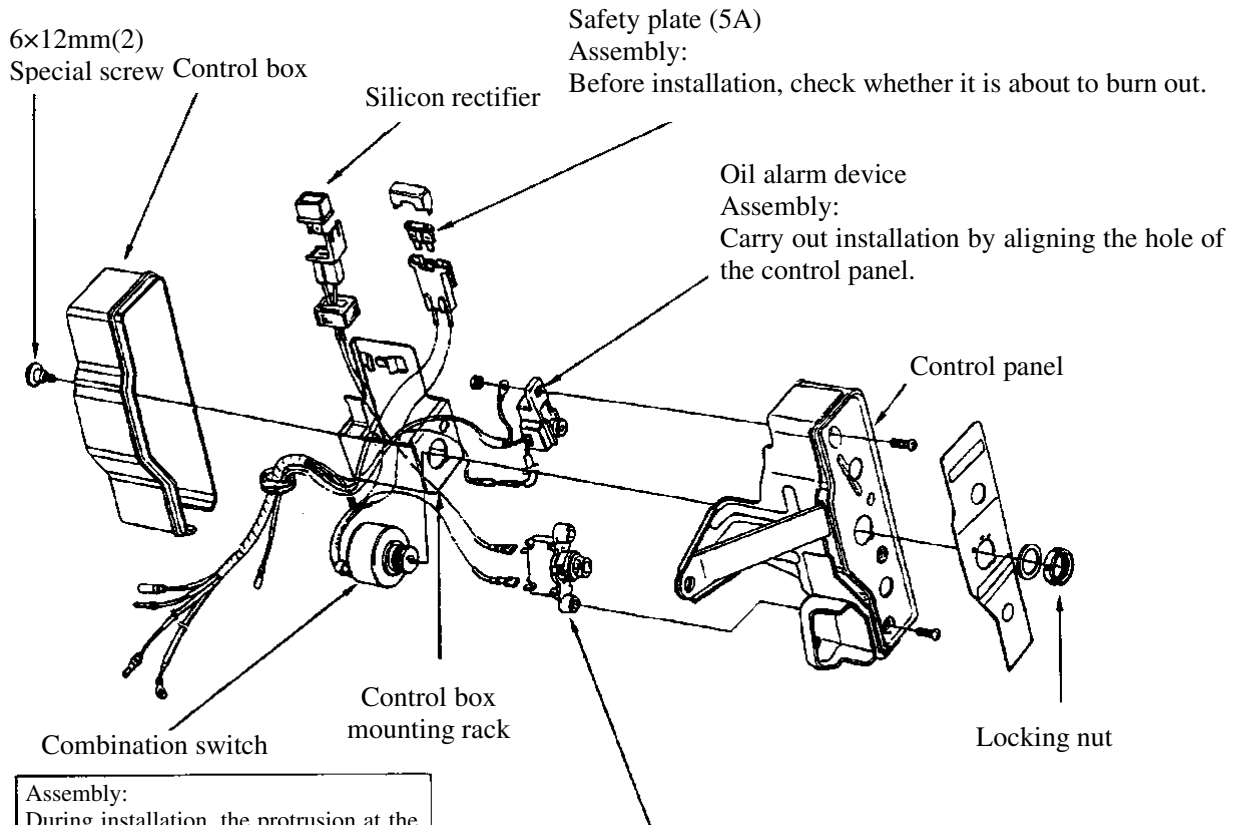

Assembly:
During installation, the protrusion at the fastening thread should be aligned with the notch of the mounting rack and the control panel.

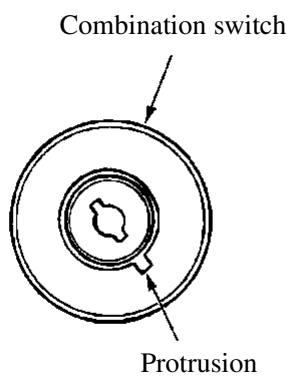

Assembly:
Be careful not to invert the left side and the right side.

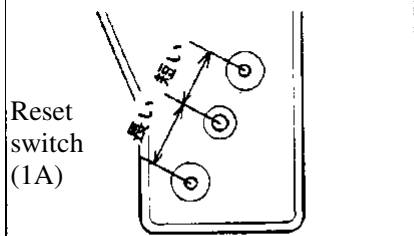

b. Inspection**• Gasoline engine switch**

Check the conduction performance between the wire and the fan guard.

Position of the gasoline engine switch	Conduction performance
ON	Non-conduction
OFF	Conduction

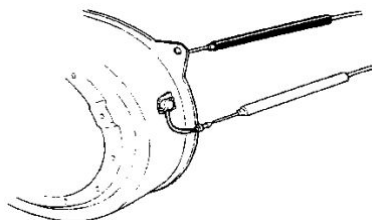
**• Gasoline engine switch (with oil alarm device)**

Check the conduction performance between the black wire and the gasoline engine switch body.

Position of the gasoline engine switch	Conduction
ON	Non-conduction
OFF	Conduction

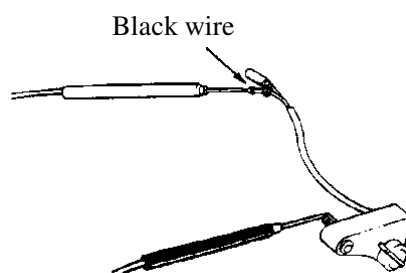
**• Combination switch (with automatic starter)**

When the switch is in each position, check the conduction performance between the wires.

Switch position	Wire color	Black/red	(Grounding)	Black/white	White
OFF		○	○	—	—
ON	Grou				
START		—	—	○	○

Inspection shall be carried out with the fuse connected.

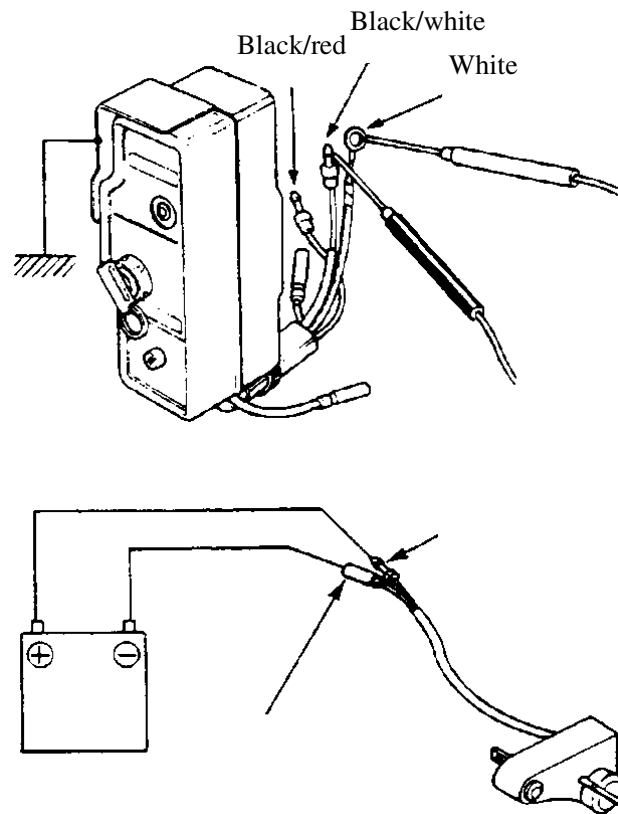

• **Oil alarm indicator**

Connect on the black/red and yellow wires of the oil alarm device.

6V battery or dry battery, make sure that the alarm indicator is on.

Black/red - (+) of the battery

Yellow - (-) of the battery

※ Never use batteries above 6V. Otherwise, the bulb will be blown.

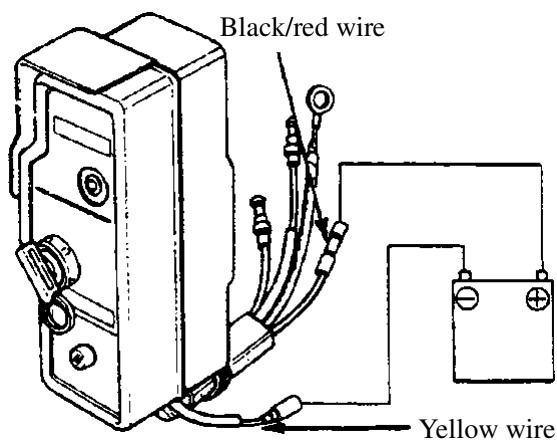

• Silicon rectifier

Check the conduction performance between the two terminals.

It is normal in case of conduction in forward direction and non-conduction in the reverse direction.

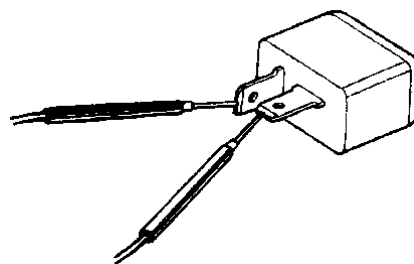

• Reset switch

With the switch in the "ON" state, confirm the conduction performance between the two terminals.

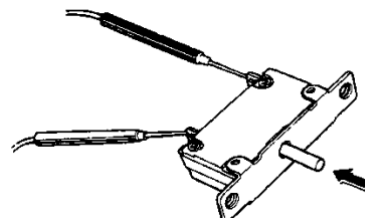

3-4-8 Starter motor

1) Disassembly and assembly

When disassembling the starter motor, please follow the above steps to disassemble the starting control box first.

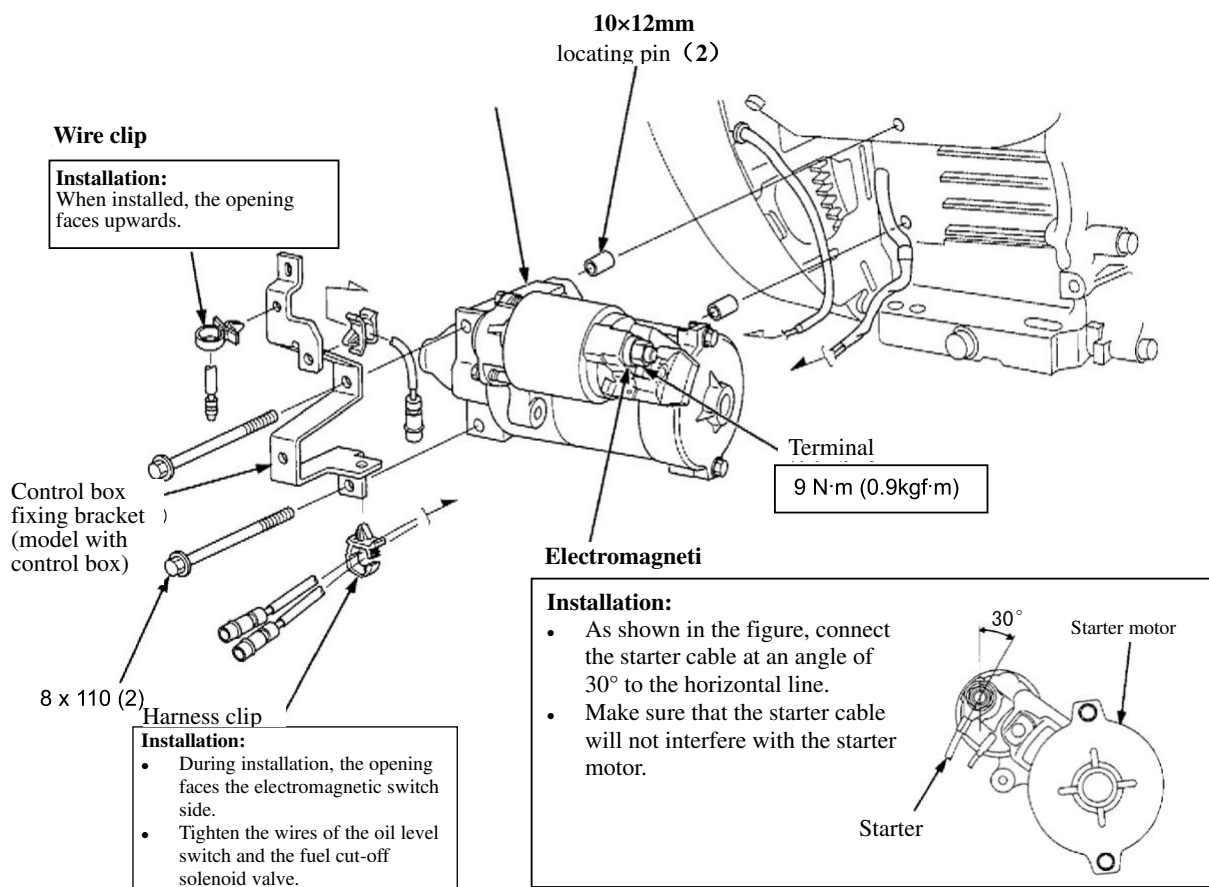

Appendix

Torque table

Item	Thread specification	Torque value (N·m)
Cylinder head assembly	M10×1.25×80	42±3
Fuel drain bolt	M12×1.5×15	24±2
Flywheel assembly	M12×1.25×35	110±5
Crankcase cover assembly	M8×50	26±2
Connecting rod cover assembly	M6×35	15±1
Cylinder head cover assembly	M6	10±1
Spark plug assembly	M14×1.25	28±2
Valve rocker arm bolt assembly	M8	24±2
Ignition coil assembly	M6×35	10±2
Valve locking nut assembly	M6	10±2
Oil sensor assembly	M6×16	9±1
Pressure sensor assembly	1/8	20±2
Muffler assembly	M8	20±2
Governing bracket assembly	M6	11±1
Other commonly used bolts	M6	10±2
Other commonly used nuts	M6	10±2
Other commonly used bolts	M8	20±2

Standard torque parameters

Fastening parts	Thread specification	Torque (N·m)
Bolts and nuts	5mm bolts and nuts	4.5-6
	6mm bolts and nuts	8-12
	8mm bolts and nuts	18-25
	10mm bolts and nuts	29-34
	12mm bolts and nuts	49-59
	4mm screws	1.5-2.6
	5mm screws	3.5-5
	6mm screws	7-11
	5mm flange bolts	3.6-6.9
	6mm screws	7-11
	5mm flange bolts	3.6-6.9
	6mm flange bolts	10-14
	8mm flange bolts	20-26
	10mm flange bolts	35-45

Chongqing RATO Technology Co., Ltd.
Address: Area B, Shuangfu Industrial Park, Jiangjin
District, Chongqing
Service hotline: 400-681-9981
Fax: 023-85553450 Postal code: 402247
Website: www.rato.cc
E-mail: ratoservice@rato.cc(service consultation)
parts@rato.cc (parts ordering)